

# **SPORTS/ART**

## 6100/E/6150/E Treadmill Repair Guide



**SPORTS ART INDUSTRIAL CO., LTD.**

SPORTS ART INDUSTRIAL CO., LTD.

## **6100/E/6150/E Series Treadmill Repair Guide**

Chapter 1. Treadmill Configuration and Wiring Diagrams

Chapter 2. Operation

Chapter 3. Error Message Definitions

Chapter 4. Measuring and Testing

6100/E/6150/E

# 1. Treadmill Configuration and Wiring Diagram

SPORTS ART INDUSTRIAL CO., LTD.

SPORTS ART INDUSTRIAL CO., LTD.

**6150E/6100E Treadmill**

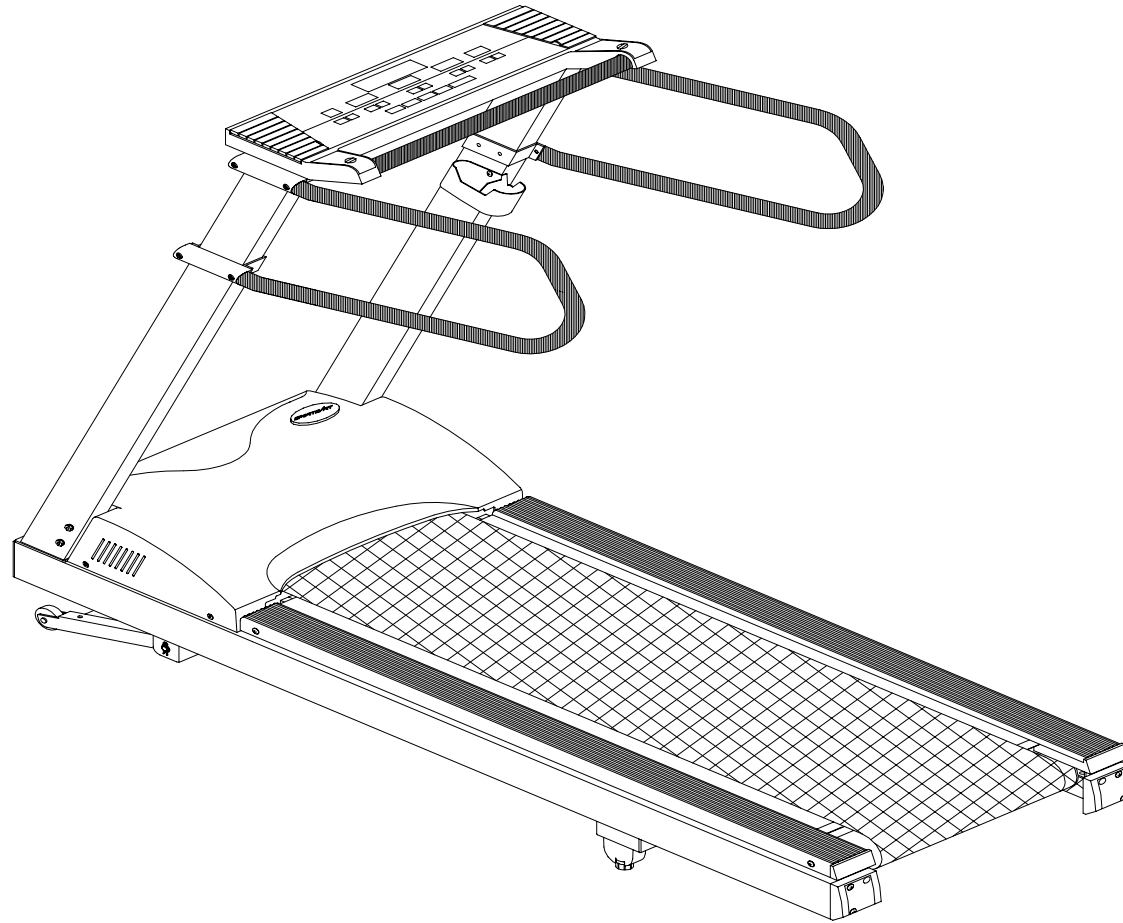



# 6150E/6100E Treadmill Electronic Component Placement Diagram

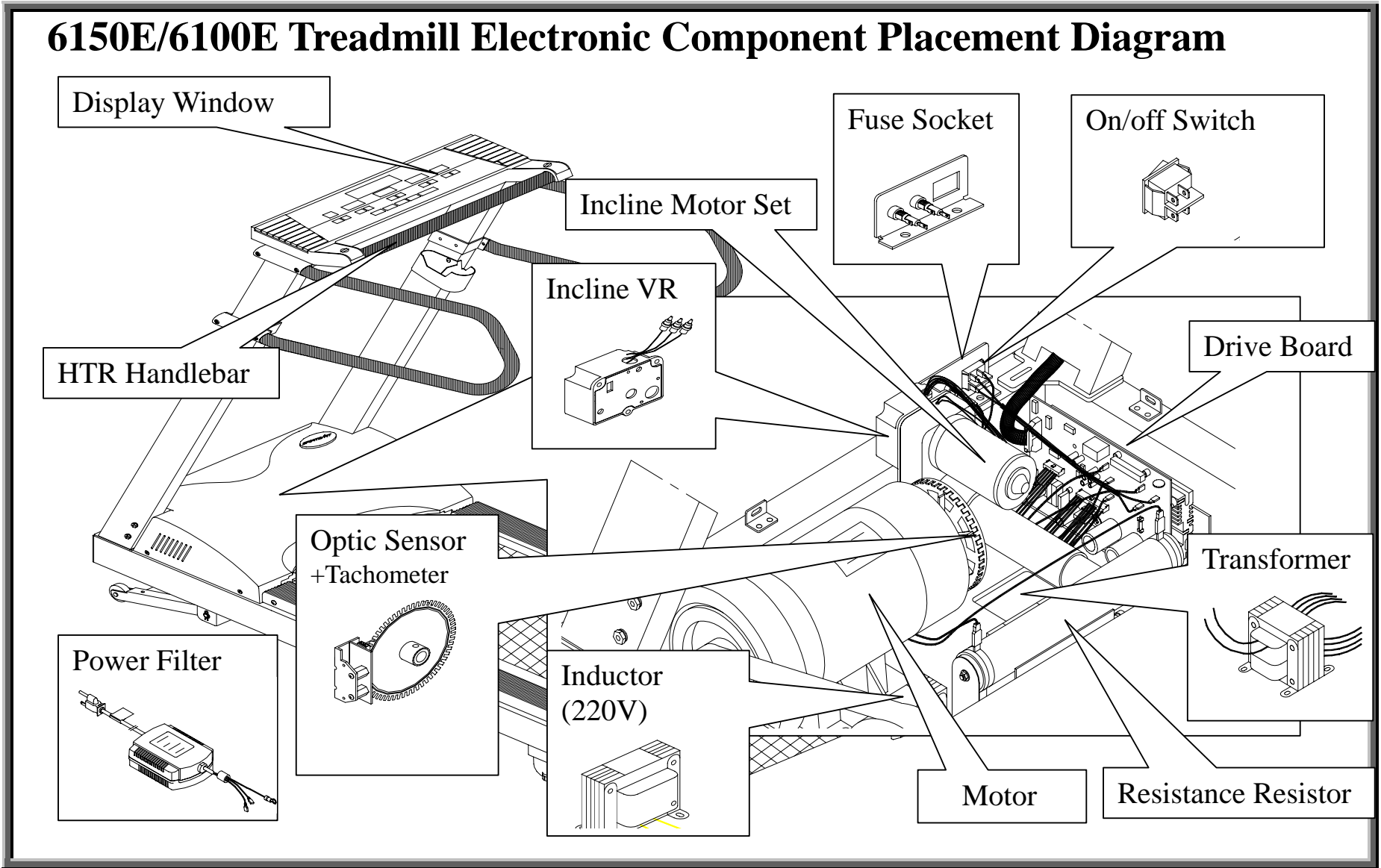

### 6150/E/6100/E Treadmill Configuration

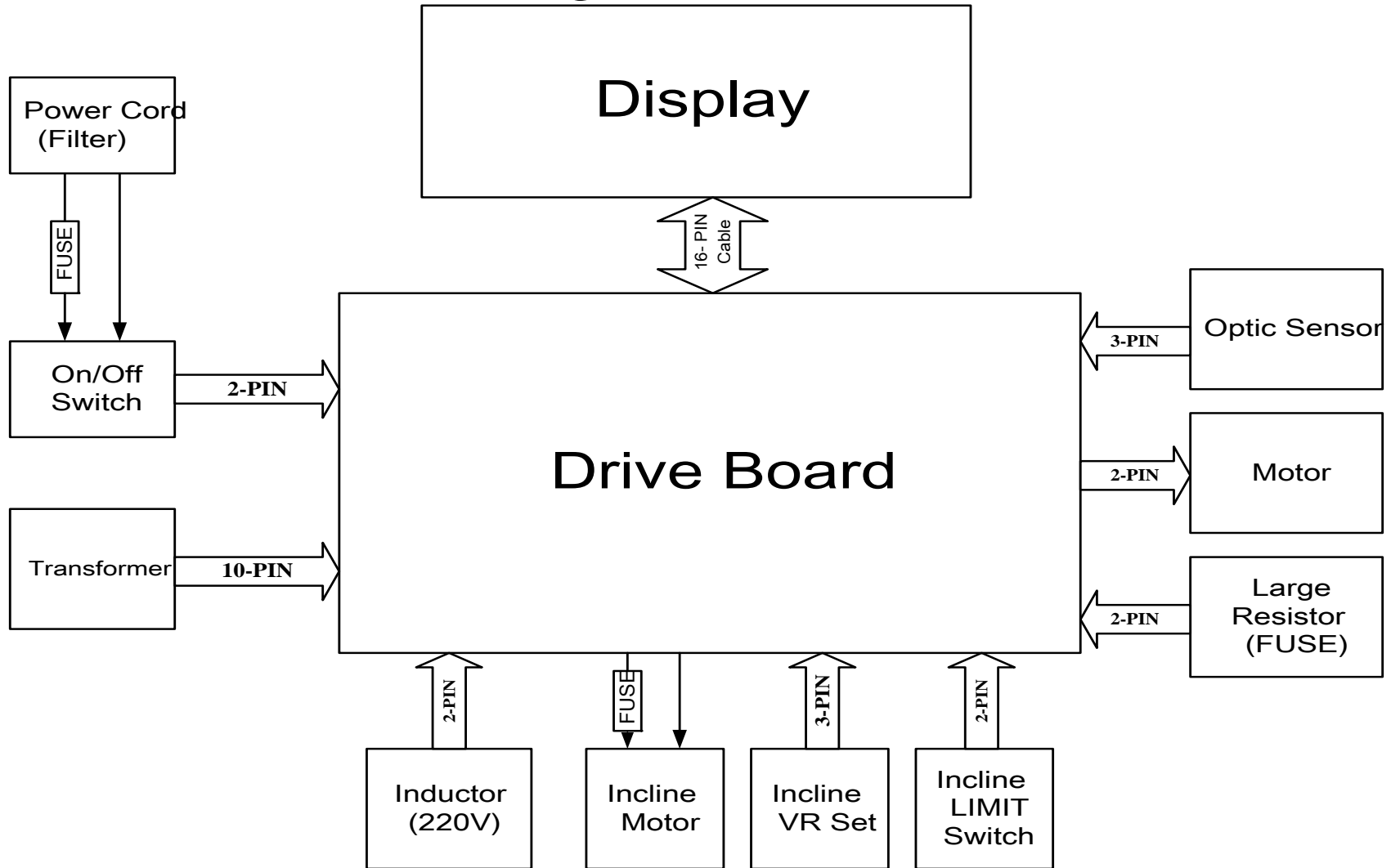

### 6150/E/6100/E Display Board Wiring Connection Diagram

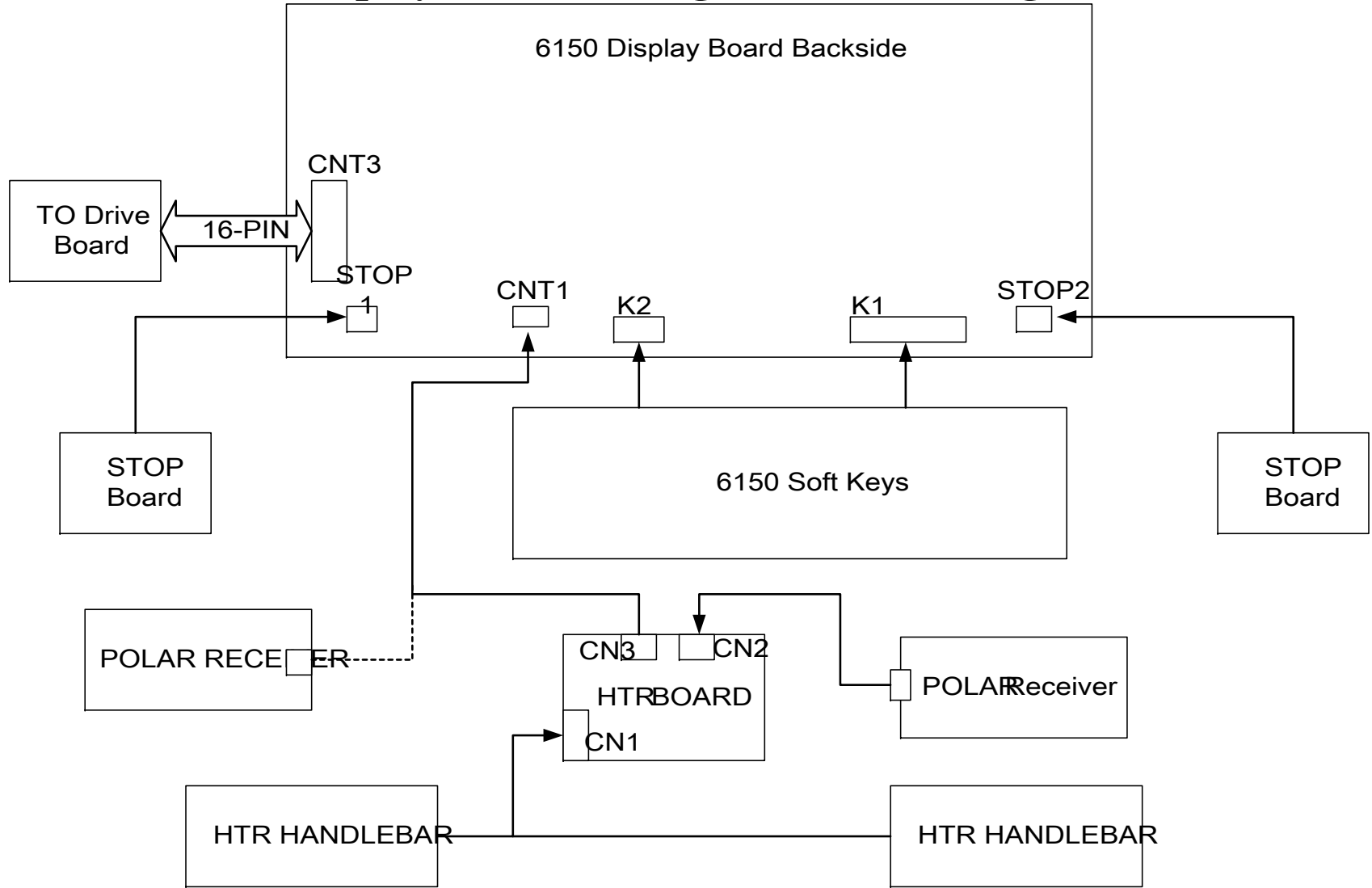

# 6150/E/6100/E Drive Board Wiring Connection Diagram

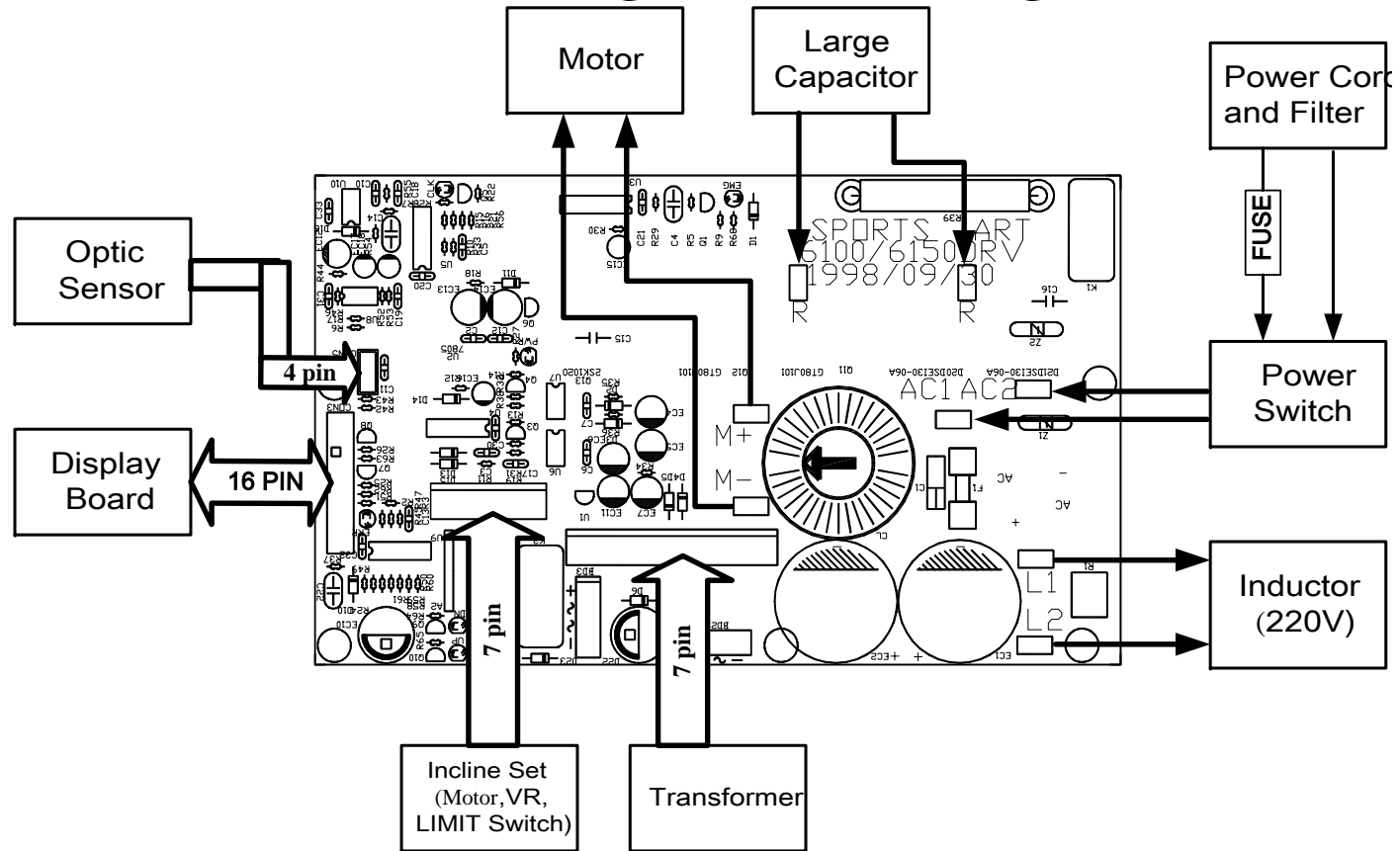

# 6150/E/6100/E Display Board Component Placement Diagram

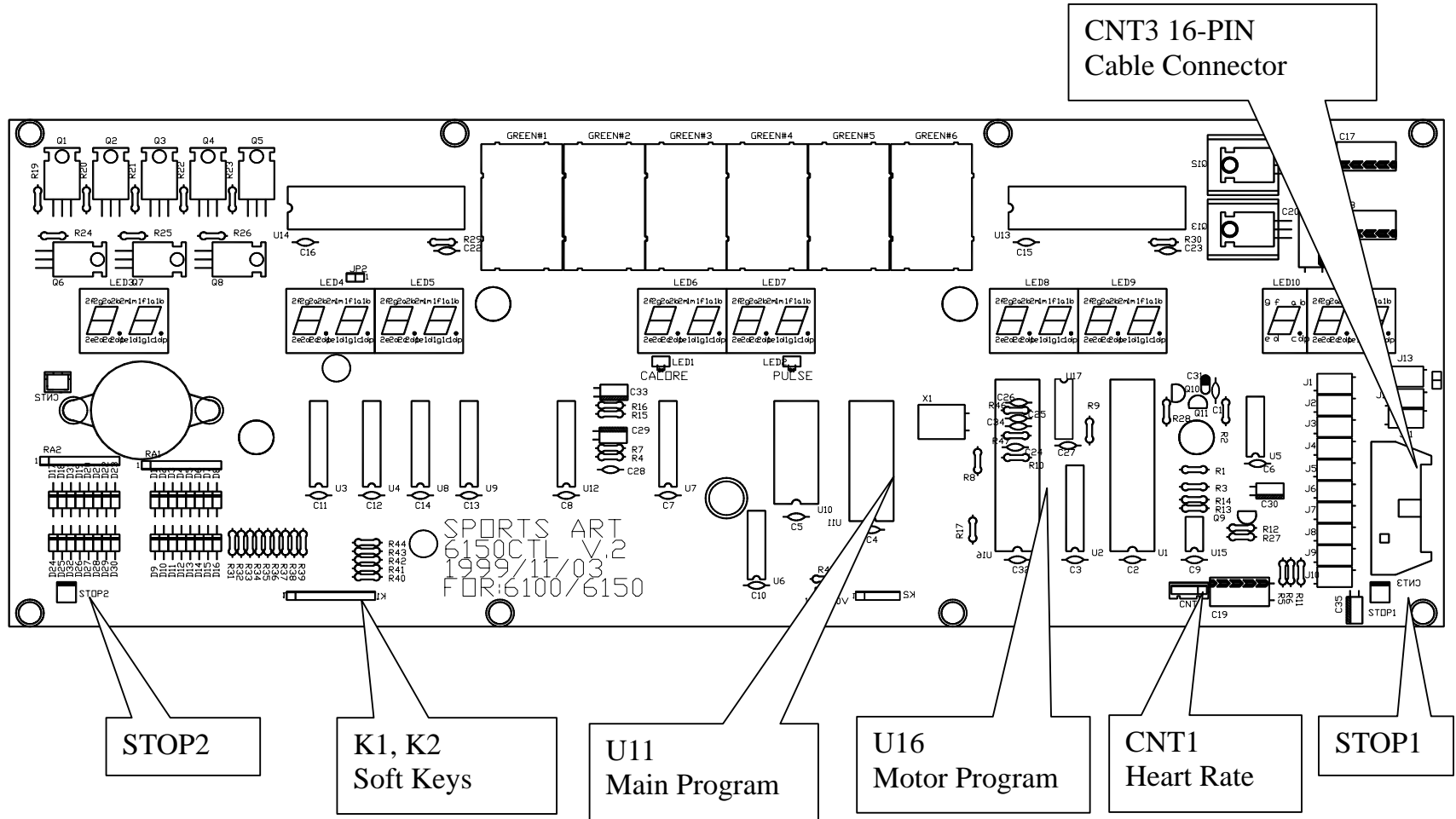

# 6150/E/6100/E Drive Board Component Placement Diagram

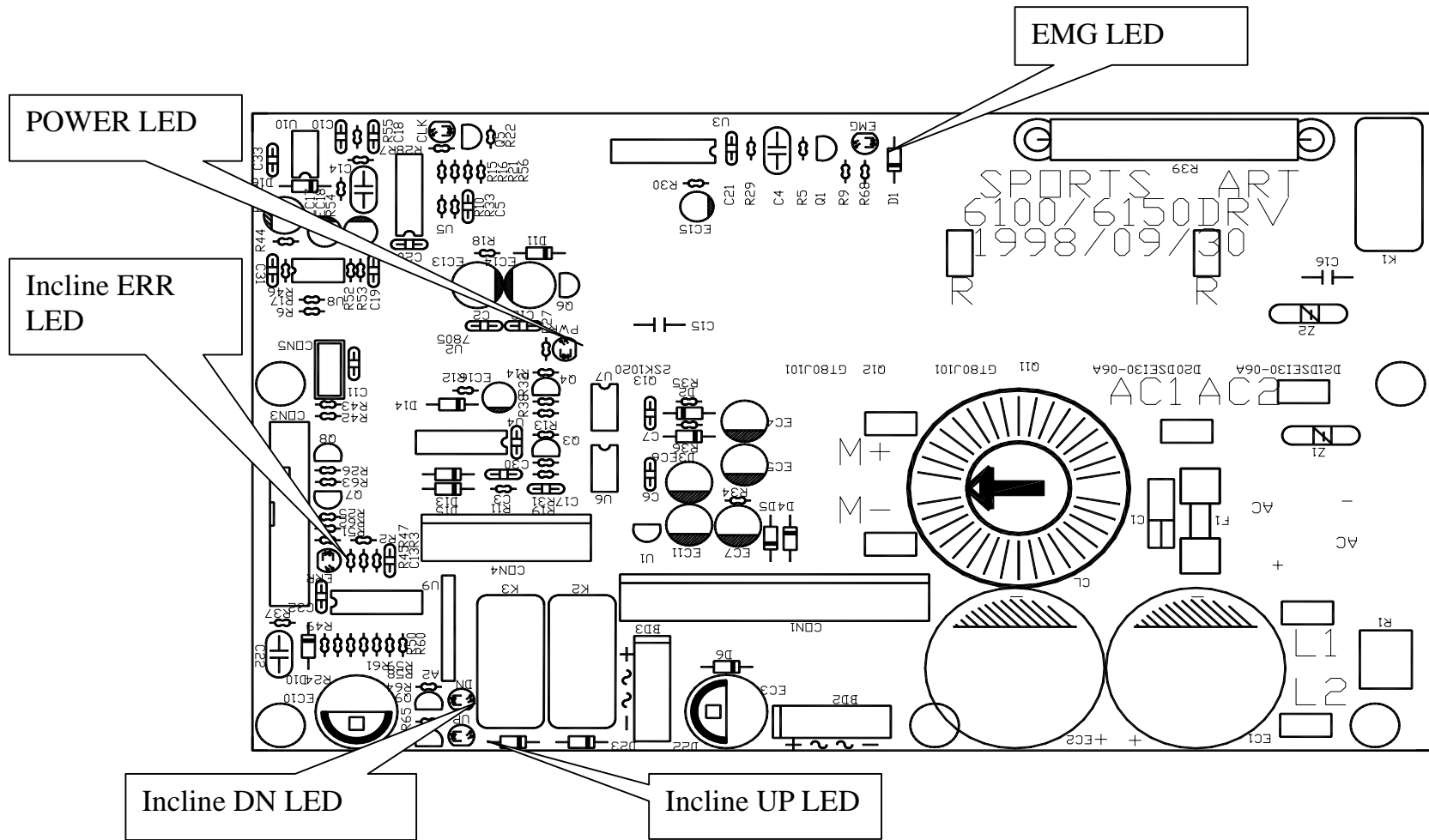

SPORTS ART INDUSTRIAL CO., LTD.

6150/E Display Panel

**PROGRAM 1-12 Program profiles(%)**

|     |   |    |    |    |   |    |    |    |    |
|-----|---|----|----|----|---|----|----|----|----|
| 1r  | 0 | 1  | 2  | 1  | 3 | 2  | 0  | 1  | 2  |
| 2r  | 0 | 3  | 0  | 3  | 4 | 2  | 0  | 4  | 7  |
| 3r  | 0 | 3  | 4  | 0  | 6 | 2  | 0  | 4  | 7  |
| 4r  | 0 | 0  | 0  | 0  | 0 | 0  | 0  | 0  | 10 |
| 5r  | 0 | 0  | 10 | 11 | 0 | 0  | 0  | 10 | 12 |
| 6r  | 0 | 0  | 10 | 15 | 0 | 0  | 0  | 7  | 15 |
| 7r  | 0 | 1  | 0  | 2  | 0 | 1  | 0  | 2  |    |
| 8r  | 0 | 3  | 4  | 0  | 0 | 0  | 4  | 0  |    |
| 9r  | 0 | 3  | 8  | 7  | 0 | 3  | 8  | 7  |    |
| 10r | 0 | 5  | 8  | 10 | 0 | 5  | 8  | 10 |    |
| 11r | 0 | 0  | 10 | 12 | 0 | 0  | 10 | 12 |    |
| 12r | 0 | 10 | 12 | 15 | 0 | 10 | 12 | 15 |    |

**PROGRAM:**  
Press **PROGRAM** key to choose desired profile, then press **ENTER**. Use **TIME** keys to input desired time. Or use **DISTANCE** keys to input desired distance. When you are done, press **ENTER** then begin your workout by pressing **SPEED** keys to start.

INCLINE

TIME

CONTROL

DISTANCE

SPEED

RACE

MANUAL SET

INTERVAL

PROGRAM

HOLD 3 SEC. TO RESET  
ENTER

CAUTION :

- Never allow children or persons unfamiliar on or near the treadmill.
- Keep hands away from moving parts.
- Care should be taken when mounting or dismounting.
- Always air dille the machine when starting the treadmill.
- If you do not have expert knowledge of this machine, please don't attempt to service this equipment.

**The RACE 1-8 LEVEL profiles(%)**

|     |   |   |   |   |   |   |   |    |   |
|-----|---|---|---|---|---|---|---|----|---|
| 1r  | 0 | 1 | 2 | 0 | 2 | 0 | 1 | 2  | 0 |
| 2r  | 0 | 1 | 2 | 0 | 1 | 2 | 0 | 1  | 2 |
| 3r  | 0 | 1 | 3 | 4 | 5 | 4 | 2 | 1  | 4 |
| 4r  | 0 | 1 | 3 | 4 | 5 | 4 | 2 | 1  | 4 |
| 5r  | 0 | 1 | 3 | 4 | 5 | 4 | 2 | 1  | 4 |
| 6r  | 0 | 2 | 0 | 3 | 0 | 7 | 0 | 10 | 7 |
| 7r  | 0 | 2 | 0 | 3 | 0 | 7 | 0 | 10 | 7 |
| 8r  | 0 | 2 | 0 | 3 | 0 | 7 | 0 | 10 | 7 |
| 9r  | 0 | 2 | 0 | 3 | 0 | 7 | 0 | 10 | 7 |
| 10r | 0 | 2 | 0 | 3 | 0 | 7 | 0 | 10 | 7 |
| 11r | 0 | 2 | 0 | 3 | 0 | 7 | 0 | 10 | 7 |
| 12r | 0 | 2 | 0 | 3 | 0 | 7 | 0 | 10 | 7 |

**RACE:**  
In RACE Mode, you can choose between LEVEL 1-8, then press **ENTER** to complete against computer. Green LED represents the computer, while yellow LED represents you. If green LED is ahead of yellow LED, that means you are leading and should speed up.

# 6100/E Display Panel

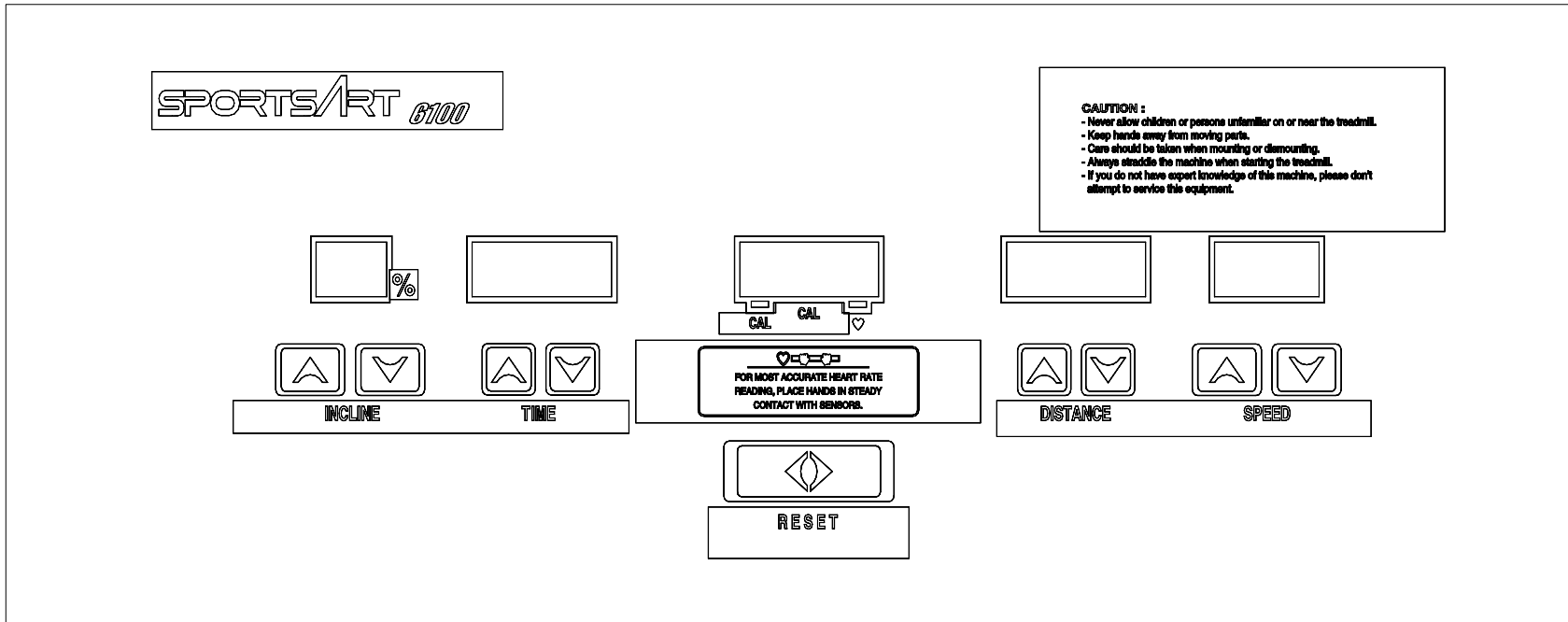



6100/E/6150/E

## 2. Operation

SPORTS ART INDUSTRIAL CO., LTD.

6100/E/6150/E

## 2. Operation

SPORTS ART INDUSTRIAL CO., LTD.

# 6150/E/6100/E Voltage Flow Chart

## 1. Configuration

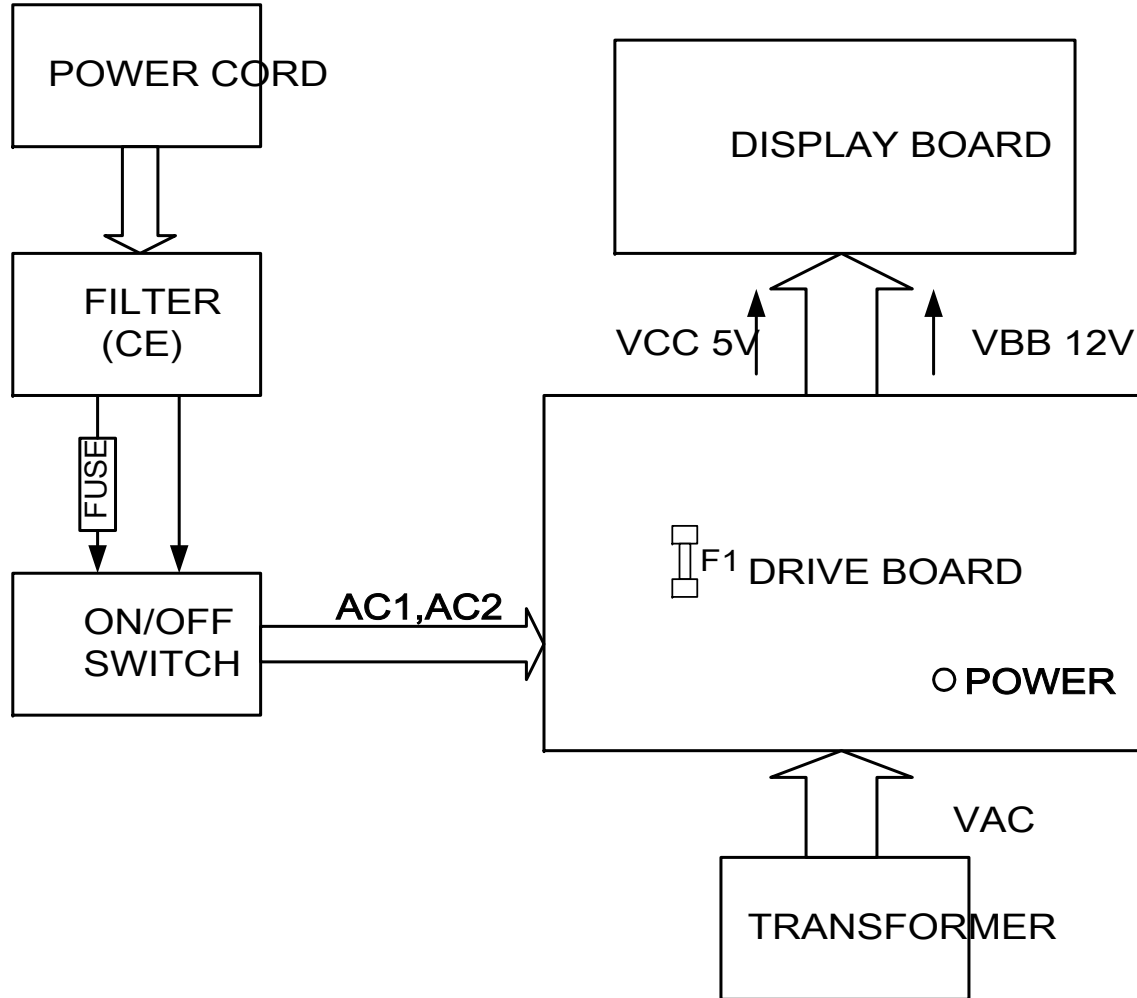

## SPORTS ART INDUSTRIAL CO., LTD.

### 2. How the Unit Operates

| Order | Name          | Operation   |
|-------|---------------|---|
| 1     | Power Cord    | 1. Brings power in from the power supply.   |
| 2     | Filter        | 1. Filters power, preventing interference (220V CE products only).  |
| 3     | Fuse          | 1. Prevents damage to components from high current.   |
| 4     | Power Switch  | 1. Turn power on "1"; power switch lights; power comes from the filter into the unit.<br>2. Turn power off "0"; power switch doesn't light; power doesn't come from the filter into the unit.   |
| 5     | Drive Board   | 1. Drive board has sent AC power through the fuse F1 to the transformer connector.<br>2. After the transformer power enters the drive board, the power is stabilized as VCC, VBB, which supplies drive and display board power.<br>3. VCC and VBB power go through the 16-PIN cable to the display board. |
| 6     | Transformer   | 1. Takes power voltage from high volt AC1, AC2 to low voltage, supplying power to components.   |
| 7     | Display Board | 1. VCC and VBB power are supplied to the display board CPU to activate the unit.<br>2. The display windows light up once it has power.  |

## SPORTS ART INDUSTRIAL CO., LTD.

### 3. Operational Procedure

| Step | Operation  |
|------|--|
| 1    | Plug unit into power supply.   |
| 2    | Turn on power, flipping switch to "1"; power light lights.                                       |
| 3    | Drive board POWER LED lights.  |
| 4    | Display board screen shows "MAN'L".  |
| 5    | Turn off power switch, flipping switch to "0"; power light doesn't light; display doesn't light. |

# 6150/E/6100/E Motor Operation Flow Chart

## 1. Configuration

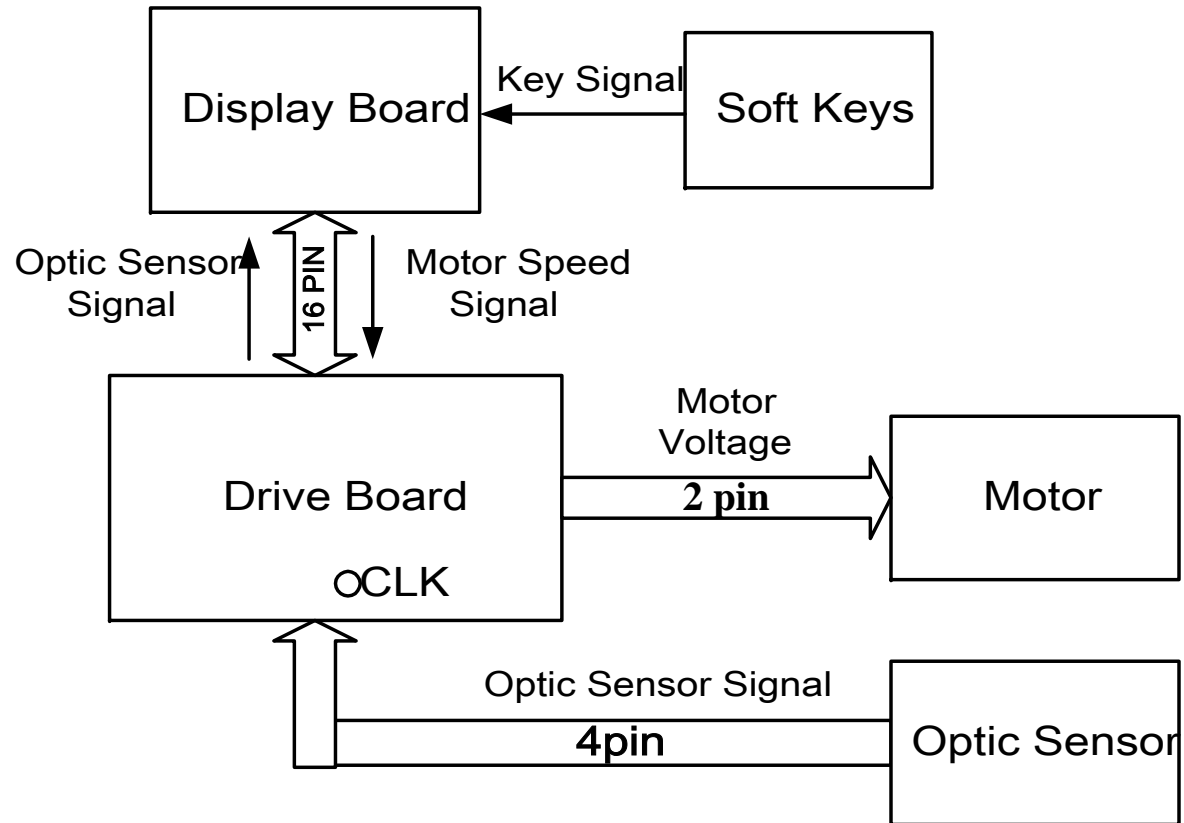

## SPORTS ART INDUSTRIAL CO., LTD.

### 2. Operational Steps

| Order | Component                | Operation   |
|-------|--------------------------|---|
| 1     | Soft Keys                | <ol style="list-style-type: none"> <li>1. User inputs the desired speed.</li> <li>2. Display board SPEED window shows SPEED key setting value.</li> </ol>   |
| 2     | Display Board            | <ol style="list-style-type: none"> <li>1. Display board CPU sends the motor speed signal to the drive board to control motor speed.</li> <li>2. The signal travels from the display board to the drive board through the 16-PIN cable.</li> </ol>   |
| 3     | Drive Board              | <ol style="list-style-type: none"> <li>1. Drive board translates the display board motor speed signal into the PWM speed signal for the display board.</li> <li>2. The PWM signal emits the drive board motor voltage to control motor speed.</li> </ol>                                  |
| 4     | Motor                    | <ol style="list-style-type: none"> <li>1. The motor rotates according to the drive board voltage.</li> <li>2. After the motor operates, the rollers turn, moving the walking belt.</li> </ol>   |
| 5     | Tach Wheel; Optic Sensor | <ol style="list-style-type: none"> <li>1. Motor operation moves the tachometer wheel.</li> <li>2. The optic sensor detect the tachometer signal.</li> <li>3. The signal travels the 4-PIN cable to the drive board.</li> </ol>  |
| 6     | Drive Board              | <ol style="list-style-type: none"> <li>1. The drive board translates the optic sensor signal from wave to rectified form.</li> <li>2. The drive board CLK indicator flashes or remains lit.</li> <li>3. The optic sensor signal travels the 16-PIN cable to the display board.</li> </ol> |
| 7     | Display Board            | <ol style="list-style-type: none"> <li>1. If the display board senses the optic sensor signal, it keeps emitting the motor signal, allowing the motor to operate.</li> </ol>  |

## SPORTS ART INDUSTRIAL CO., LTD.

### 3. Operational Procedure

| Step | Operation   |
|------|---|
| 1    | Press SPEED<▲> or SPEED<▼> key  |
| 2    | Display board SPEED window setting speed value appears.                             |
| 3    | Motor starts operating; the tachometer wheel moves, and the treadmill belt rotates. |
| 4    | Drive board CLK indicator lights.   |
| 5    | The display doesn't show any error message; the motor continues to operate.         |



# 6150/E/6100/E Incline Operation Flow Chart

## 1. Configuration

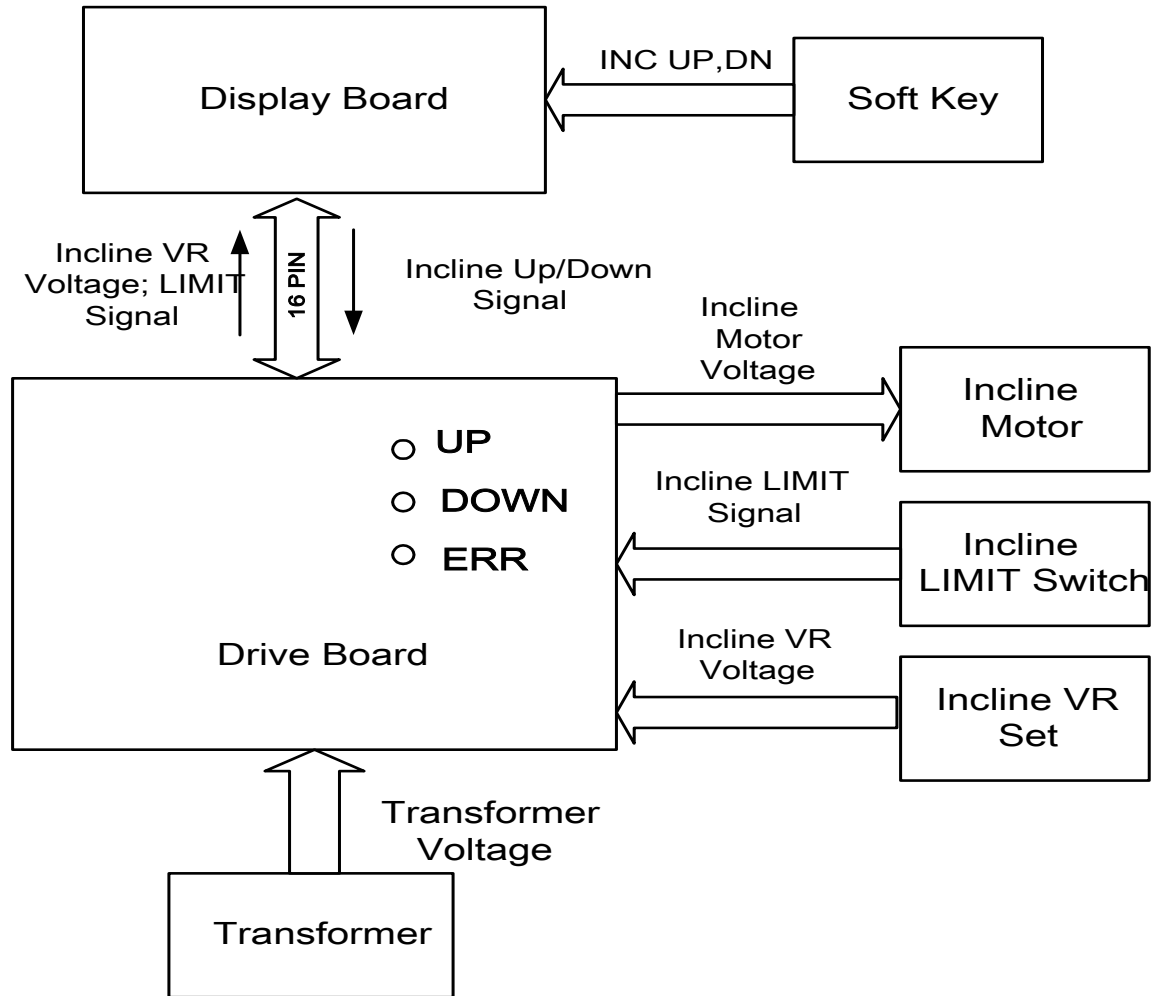

## SPORTS ART INDUSTRIAL CO., LTD.

### 1. Operation

| Order | Part           | Operation  |
|-------|----------------|--|
| 1     | Soft Keys      | 1. User inputs incline height through the keys.  |
| 2     | Display Board  | 1. The display board CPU sends the incline height setting signal to the drive board to command incline action.<br>2. The signal travels from the display board through the 16-PIN cable to the drive board.  |
| 3     | Transformer    | 1. The transformer provides the incline motor with power to operate.   |
| 4     | Drive Board    | 1. The drive board incline circuit operates according to the incline signal from the display board.<br>2. By changing the polarity of the voltage, the drive board makes the DC incline motor turn up or down.<br>3. The drive board UP indicator lights to indicate up incline action.<br>4. The drive board DN indicator lights to indicate down incline action.   |
| 5     | Incline VR Set | 1. The incline gears turn, turning the VR, which increases or decreases the incline value.<br>2. Incline height is determined according to the incline VR value voltage.   |
| 6     | LIMIT          | 1. When the incline motor leaves the incline VR value range, the incline VR gear hits the LIMIT switch.<br>2. A broken LIMIT switch circuit means that the incline set has exceeded its range.   |
| 7     | Drive Board    | 1. The incline LIMIT signal enters the drive board for processing. If the LIMIT switch circuit is short (normal), then ERR indicator doesn't light. If the LIMIT switch circuit is broken (not normal), the ERR indicator lights.<br>2. If the ERR indicator lights, incline action immediately stops.<br>3. The incline VR wire VR value enters the drive board.<br>4. The incline LIMIT signal and VR value travels the 16-PIN cable to the display board. |
| 8     | Display Board  | 1. The display board senses the VR value and constantly emits the incline signal.<br>2. The signal is emitted until the incline VR value and the setting value are the same. Once these are the same, the signal stops, and the incline action stops.  |

## SPORTS ART INDUSTRIAL CO., LTD.

### 3. Operational Steps

| Step | Operation   |
|------|---|
| 1    | Press the INCL<▲> or INCL<▼> key.                                     |
| 2    | Display board INCL window shows incline value setting.                |
| 3    | Drive board UP or DOWN indicator lights; ERR indicator doesn't light. |
| 4    | Incline action begins.  |
| 5    | Once the incline position is reached, action stops.                   |

# 6150/E/6100/E Motor/Resistor Operation Flow Chart

## 1. Configuration

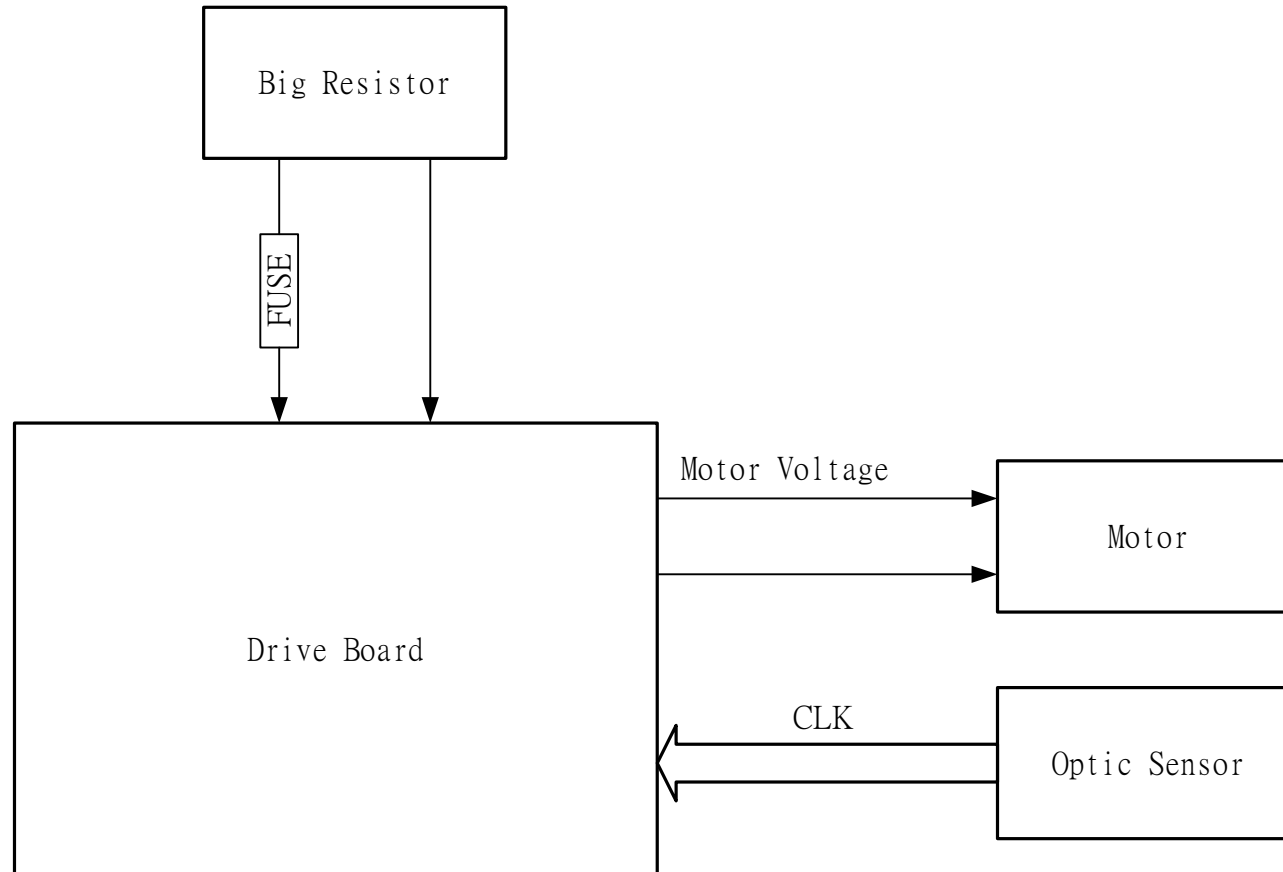

## SPORTS ART INDUSTRIAL CO., LTD.

### 2. Operation

| Order | Name         | Operation   |
|-------|--------------|---|
| 1     | Motor        | 1. When the treadmill motor is operating, if the belt is pulled, the motor will speed up.   |
| 2     | Optic Sensor | 1. When the motor speeds up, the optic sensor signal speeds up.<br>2. The optic sensor signal travels the 4-PIN cable to the drive board.   |
| 3     | Drive Board  | 1. When the drive board receives the optic sensor signal, if the signal and the setting differ, the drive board creates a resistance signal and the drive resistance (large resistor) operates. |
| 4     | Motor        | 1. When the resistor operates, the motor amp draw creates resistance.<br>2. If the user pulls the belt, the treadmill belt speed doesn't increase; resistance is felt.                          |

### 3. Operational Procedure

| Steps | Operation   |
|-------|---|
| 1     | Pulling the belt increases belt speed.                              |
| 2     | Resistance is created, and the treadmill belt speed is held steady. |

## 6100/E/6150/E Display Key Function Flow Chart

### 1. Configuration

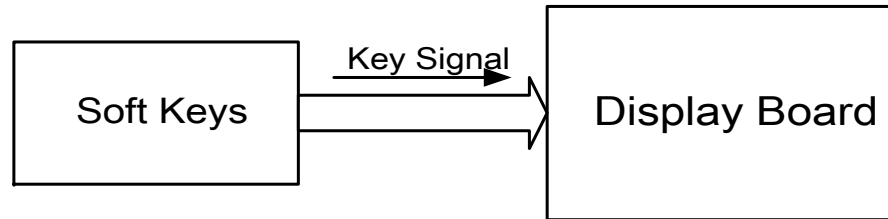

### 2. Operation

| Name          | Operation  |
|---------------|--|
| Soft Keys     | 1.Press the display soft keys.<br>2.The keys send their signal to the display board. |
| Display Board | 1.The key signal is read by the CPU.<br>2. The CPU implements the key signal action. |

## SPORTS ART INDUSTRIAL CO., LTD.

### 3. Operational Steps

| Key              | Operation   |
|------------------|---|
| INCL<▲> key      | Continuously press INCL<▲> key; the INCL window value increases to 15.  |
| INCL<▼> key      | Continuously press INCL<▼> key; the INCL window value decreases to 0.   |
| TIME<▲> key      | Continuously press TIME<▲> key; the TIME window value increases to 99.00.   |
| TIME<▼> key      | Continuously press TIME<▼> key; the TIME window value decreases to 0000.  |
| DIST<▲> key      | Continuously press DIST<▲> key; the LOAD window value increases to 999.0.   |
| DIST<▼> key      | Continuously press DIST<▼> key; the LOAD window value decreases to 0000.  |
| SPEED<▲> key     | Continuously press SPEED<▲> key; the SPEED window value increases to 20.0KPH (16.0MPH).   |
| SPEED<▼> key     | Continuously press SPEED<▼> key; the SPEED window value decreases to 0.2KPH (0.1MPH).   |
| <RACE> key       | Continuously press <RACE> key; the main display window shows “LEVEL 1”-“LEVEL 8”.   |
| <MANUAL/SET> key | Continuously press <MAN'L> key; the main display window:<br>(1) switches between “MAN'L”/”SET” notices (No HRC function units)<br>(2) switches between “MAN'L”/”SET”/”HRC” (HRC function units) |
| <INTERVAL> key   | Continuously press <INTV> key; the main display window switches between “INTV1”/”INTV2” notices.  |
| <PROGRAM> key    | Continuously press <PROG> key; the main display window shows “PRO 1” - ”PRO12” in order.  |
| <RESET> key      | Continuously press <RESET> key three seconds; the display beeps; the main display window shows; the small window deletes to 0.  |

## 6100/E/6150/E POLAR Heart Rate Operation Flow Chart

### 1. Configuration

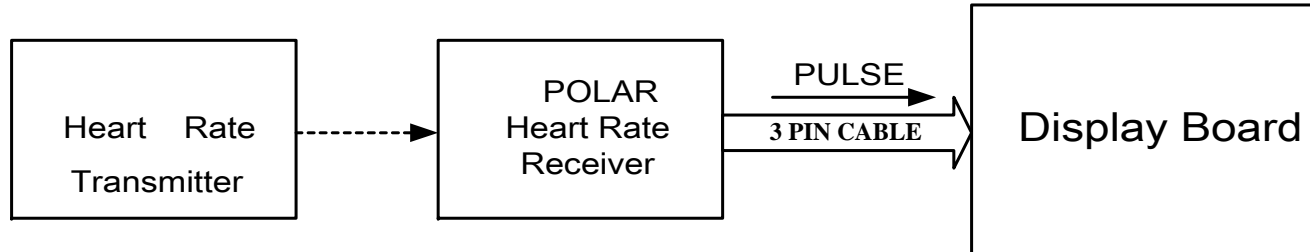

### 2. Operational Procedure

| Part                      | Operation   |
|---------------------------|---|
| Heart Rate Transmitter    | 1. Put on the POLAR transmitter.<br>2. The POLAR transmitter senses the wearer's heart beat and transmits the heart rate to the receiver.<br>3. POLAR heart rate transmitter transmits within a distance of 90 centimeters. |
| POLAR Heart Rate Receiver | 1. POLAR receiver receives the signal from the transmitter through a wireless transmission.<br>2. After the heart rate signal is processed, it travels the 3-PIN cable to the display board.                                |
| Display Board             | 1. After receiving and processing the heart rate signal, it is sent to the program which then determines the heart rate value.<br>2. The display board PULSE window shows the heart rate value.                             |



## SPORTS ART INDUSTRIAL CO., LTD.

### 3. Operational Procedure

| Step | Operation  |
|------|--|
| 1    | Put on the POLAR transmitter; stand on the treadmill.          |
| 2    | Within 5 seconds, the PULSE window shows the heart rate value. |

# 6100/E/6150/E Display Board HTR Heart Rate Flow Chart

## 1. Configuration

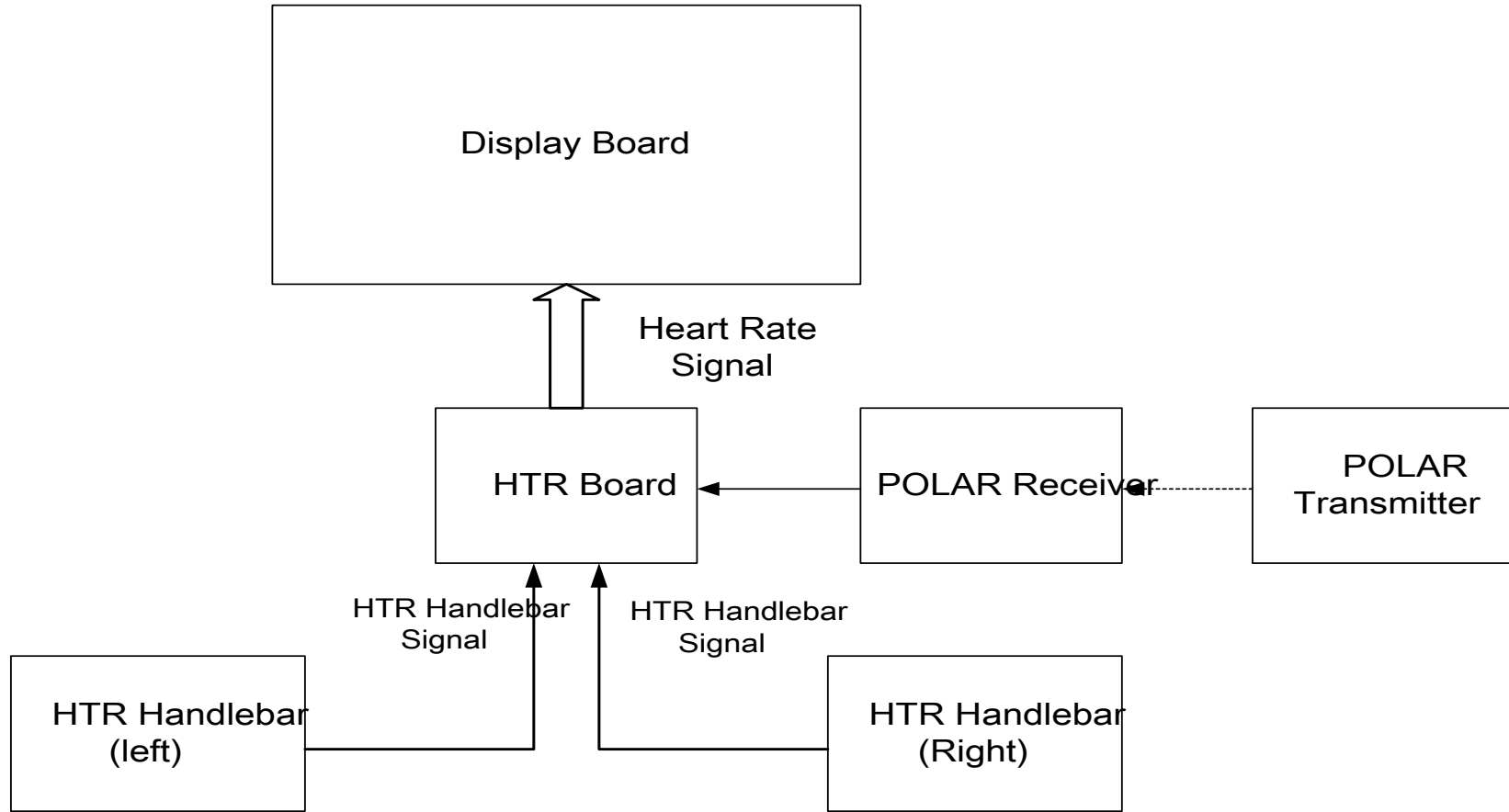

## SPORTS ART INDUSTRIAL CO., LTD.

### 2.HTR Operation

| Name           | Operation  |
|----------------|--|
| HTR HANDLE BAR | 1. Put both hands on the HTR handlebar. The user's pulse signal travels from the HANDLE BAR to the HTR small board.  |
| HTR Board      | 1. The HTR board translates the pulse into the heart rate signal.<br>2. The HTR board indicator lights, showing the heart rate. Please refer to the HTR explanation. |
| Display Board  | 1.The heart rate signal is read by the program.<br>2.The display PULSE window shows the pulse value.   |

### 3. POLAR Heart Rate Operation

| Name                         | Operation  |
|------------------------------|--|
| POLAR Heart Rate Transmitter | 1.The heart rate transmitter senses the pulse signal.<br>2.The transmitter sends the pulse signal to the receiver.               |
| Heart Rate Receiver          | 1.The receiver receives the heart rate signal.<br>2. The receiver sends the signal through the 3-pin cable to the display board. |
| Display Board                | 1. The CPU determines the heart rate value.<br>2. The display PULSE window shows the heart rate value.                           |

SPORTS ART INDUSTRIAL CO., LTD.

4. HTR Operation Procedure

| Step | Operation   |
|------|---|
| 1    | Hold onto the handlebar   |
| 2    | HTR small board D4 indicator lights; D5 and D6 indicators continue to flash.  |
| 3    | The PULSE window shows the HR value within about 10 seconds.  |
| 4    | Take your hand off the handlebar; within about 5 minutes, the PULSE window shows the base display with no HR value. |

5.POLAR Operation

| Step | Operation  |
|------|--|
| 1    | Put POLAR strap in place; Don't hold onto the HTR handlebar.     |
| 2    | Stand on the treadmill.  |
| 3    | The PULSE window signal lights and the heart rate value appears. |

# 6100/E/6150 STOP Switch Flow Chart

## 1. Configuration

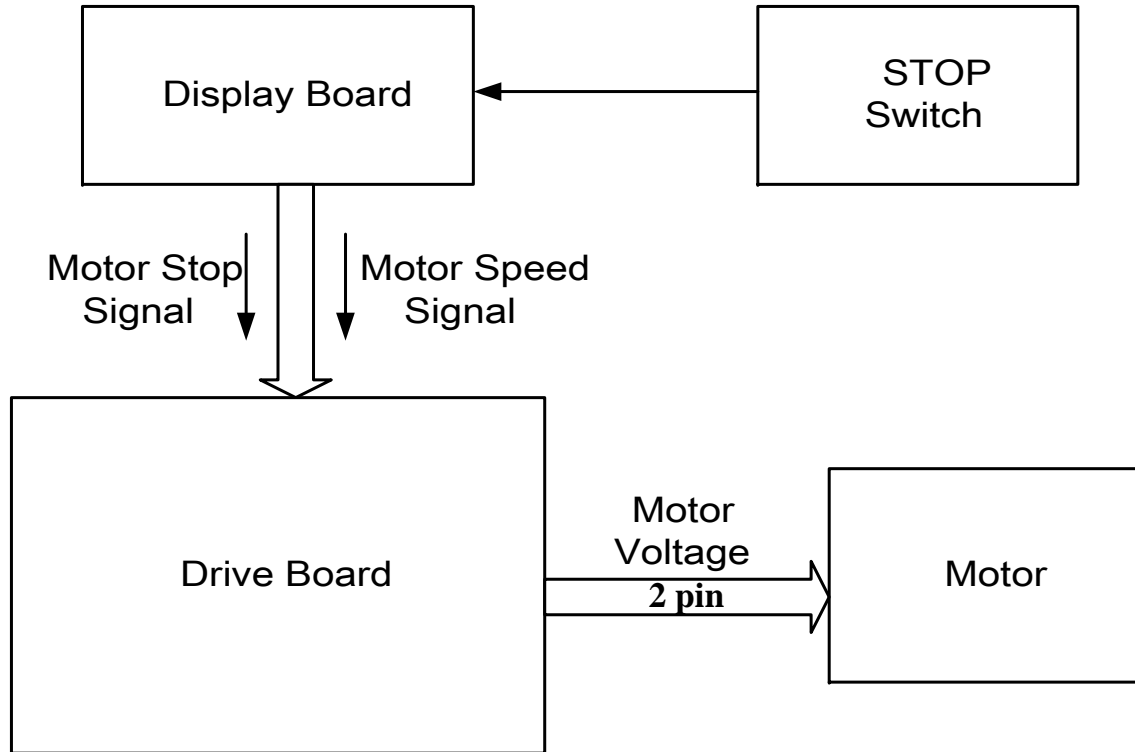

## SPORTS ART INDUSTRIAL CO., LTD.

### 2. Operation

| Order | Part Name     | Operation   |
|-------|---------------|---|
| 1     | STOP Switch   | 1. Hit the STOP pad.<br>2. STOP switch operates, sending its signal to the display board.   |
| 2     | Display Board | 1. The display board sends the STOP signal to the CPU for determination.<br>2. When the display detects the STOP switch operation, SPEED window shows "0.0" (flashing); Other windows remain unchanged with memory preserved.<br>3. The CPU sends the motor stop signal to the drive board. |
| 3     | Drive Board   | 1. After receiving the motor stop signal, the drive board stops emitting the motor drive voltage.   |
| 4     | Motor         | 1. Once the motor doesn't have power from the drive board, it stops operating.  |

### 3. Operation Procedure

| Step | Operation   |
|------|---|
| 1    | 1. Press SPEED<▲>; The motor operates.  |
| 2    | 1. Press the display left or right STOP switch; the display board SPEED window shows "0.00" (flashing).<br>2. Other windows remain unchanged with memory preserved. |
| 3    | 1. Motor stops operating.   |

# 6150/E/6100/E Incline Function Protection Flow Chart

## 1. Configuration

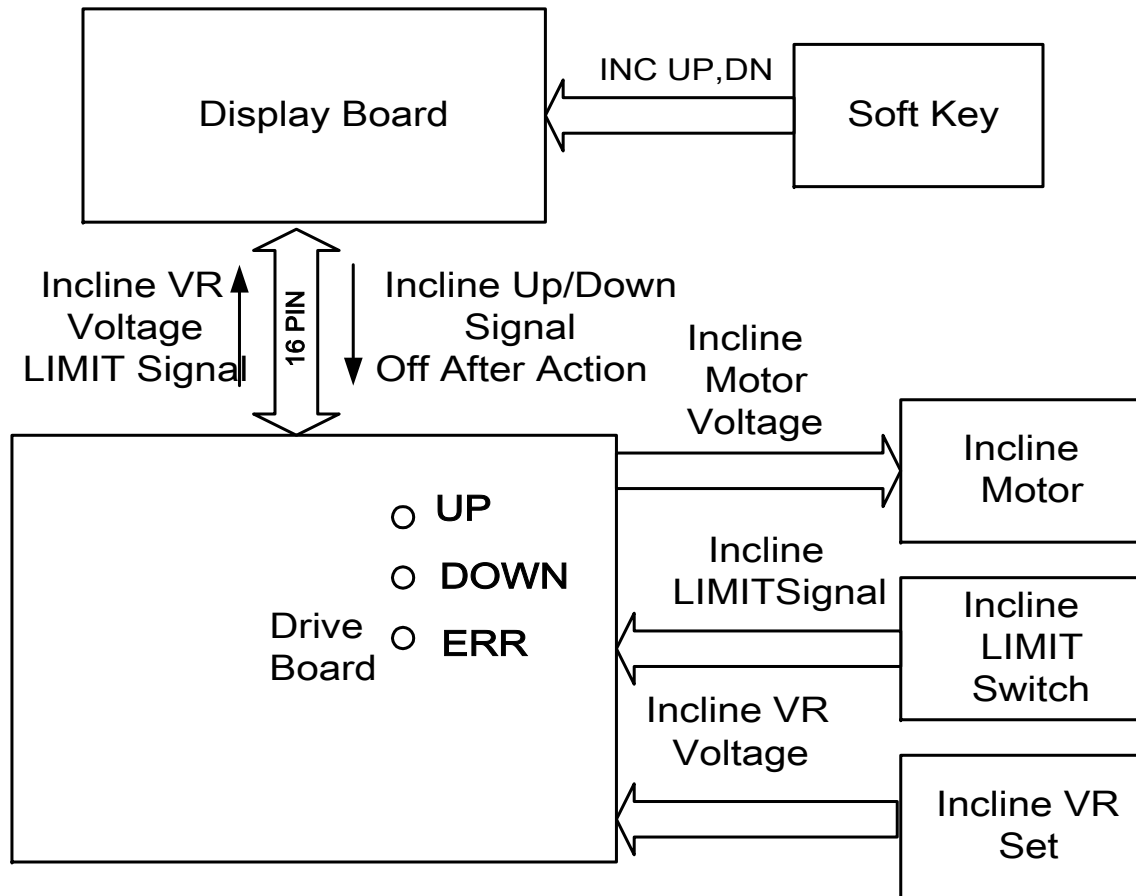

## SPORTS ART INDUSTRIAL CO., LTD.

### 2. Operation

#### 2-1. Incline action activates the incline protection function.

| Order | Name           | Operation  |
|-------|----------------|--|
| 1     | Soft keys      | 1. Pressing INCL<▲> or INCL<▼> key causes incline action.  |
| 2     | Display board  | 1. Display board CPU sends the incline up/down signal to the drive board, thus controlling incline action.<br>2. The signal travels the 16-PIN cable from the control to display board.  |
| 3     | Drive board    | 1. The drive board incline circuit operates according to the display board incline signal.<br>2. By changing the output voltage polarity, the drive board makes the DC incline motor turn clockwise or counterclockwise.<br>3. When in up incline action, the drive board UP signal lights.<br>4. When in down incline action, the drive board DOWN indicator lights.  |
| 4     | Incline VR set | 1. When the incline gears turn, the VR turns, and the VR value increases or decreases.<br>2. The VR uses the VR value voltage to determine incline position.   |
| 5     | LIMIT          | 1. When the incline motor range exceeds the VR value range, the gears in the incline VR set hit the LIMIT switch.<br>2. A broken LIMIT switch circuit means that the incline height range has been exceeded.   |
| 6     | Drive board    | 1. The incline LIMIT signal enters the drive board for processing; If the LIMIT switch circuit is short (normal), the ERR light doesn't light; If the LIMIT switch circuit is broken (abnormal), the ERR indicator lights.<br>2. During incline operation, if the ERR indicator lights, incline action immediately stops.<br>3. The incline VR value enters the drive board through the VR wire.<br>4. The incline LIMIT signal and VR value travel the 16-PIN cable to the display board. |
| 7     | Display board  | 1. The display board senses the LIMIT signal action, stopping incline signal action.<br>2. The display board INCL window shows height at the time of LIMIT action.   |



SPORTS ART INDUSTRIAL CO., LTD.

2-2. Drive board ERR indicator lights, incline protection function acts

| Order | Name          | Operation  |
|-------|---------------|--|
| 1     | Incline LIMIT | 1. When incline height exceeds the range, the LIMIT switch operates (broken circuit).<br>2. The LIMIT signal travels the incline cable to the drive board.   |
| 2     | Drive Board   | 1. The drive board detects LIMIT signal operation, and ERR indicator lights.<br>2. The signal travels the 16-pin cable to the display board.   |
| 3     | Display board | 1. When the display board senses LIMIT signal operation, the program implements incline protection.<br>2. When incline protection is activated, only one direction will operate when incline keys are pressed.<br>3. Once the LIMIT signal is not activated, incline action resumes. |

## SPORTS ART INDUSTRIAL CO., LTD.

### 1. Operation

#### 3-1. Activating incline protection during incline operation

| Step | Operation  |
|------|--|
| 1    | Press INCL<▲> or INCL<▼> key; Incline up or down operates.   |
| 2    | Before incline action stops, the incline LIMIT switch signal operates (LIMIT yellow wire connection removed) |
| 3    | Drive board ERR indicator lights, incline action immediately stops.  |
| 4    | Display board INCL window shows actual incline position.   |

#### 3-2. Activating incline protection after the drive board ERR indicator lights

| Step | Operation   |
|------|---|
| 1    | Incline LIMIT signal is broken (LIMIT yellow wire connection removed)   |
| 2    | Drive board ERR indicator lights.   |
| 3    | Press display INCL<▲> or INCL<▼> key; Incline window numerical values only change in one direction.               |
| 4    | The drive board UP or DN indicator lights; Incline operates.  |
| 5    | Reconnect the LIMIT yellow switch; The drive board ERR indicator doesn't light.                                   |
| 6    | Press INCL<▲> or INCL<▼> key; The incline window operates normally, with incline values increasing or decreasing. |

6100/E/6150/E

### 3. Error Message Definitions

SPORTS ART INDUSTRIAL CO., LTD.

## 6100/E/6150/E Error Message Definition : ERR 1

**Definition :** Display board CPU has not received the optic sensor signal.

### 2. Configuration

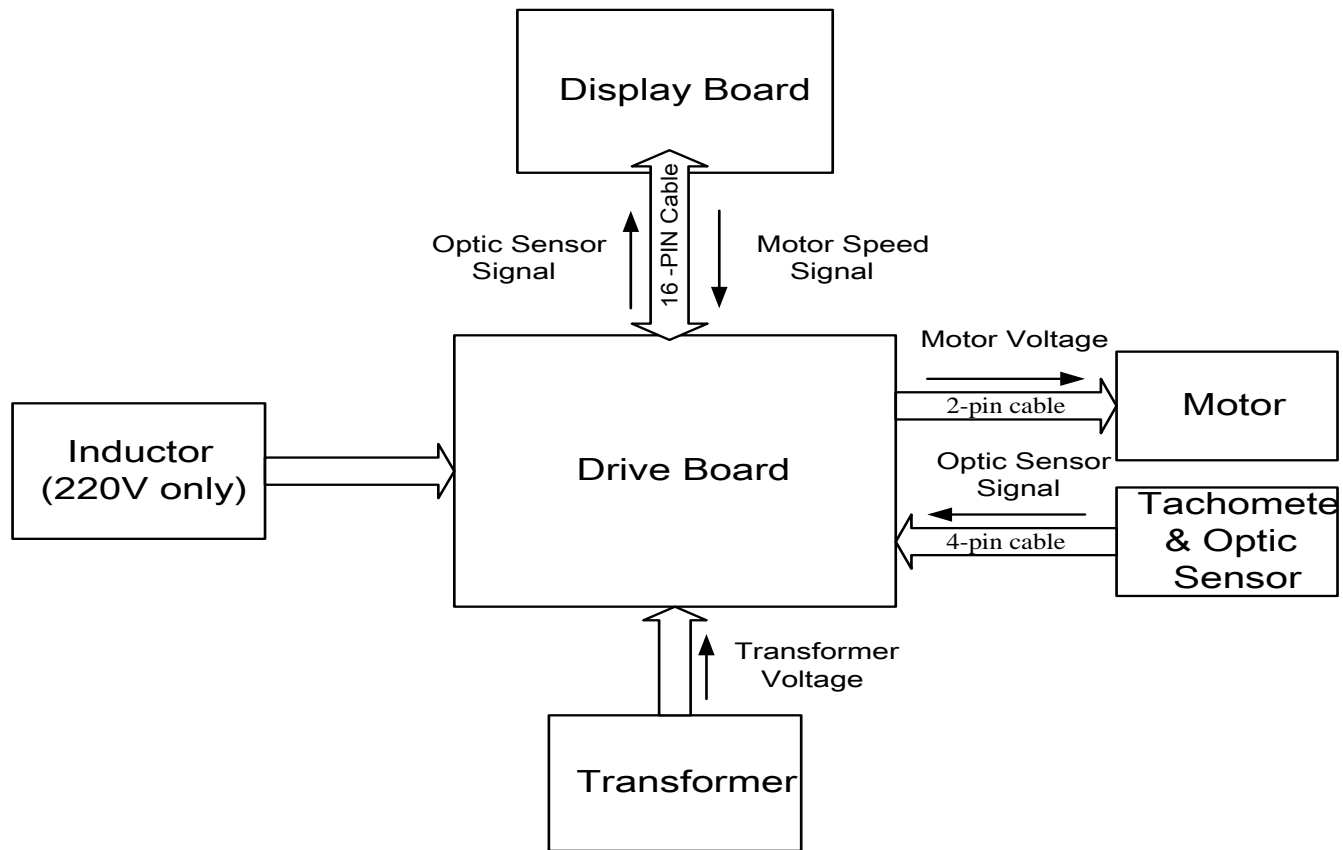

## SPORTS ART INDUSTRIAL CO., LTD.

### 3. Explanation for ERR1

1. Motor doesn't operate; ERR1 appears.

#### 1-1. Explanation :

Drive board has not sent power to the motor, so the motor doesn't operate; the optic sensor signal hasn't returned to the display board.

#### 2-1. Configuration

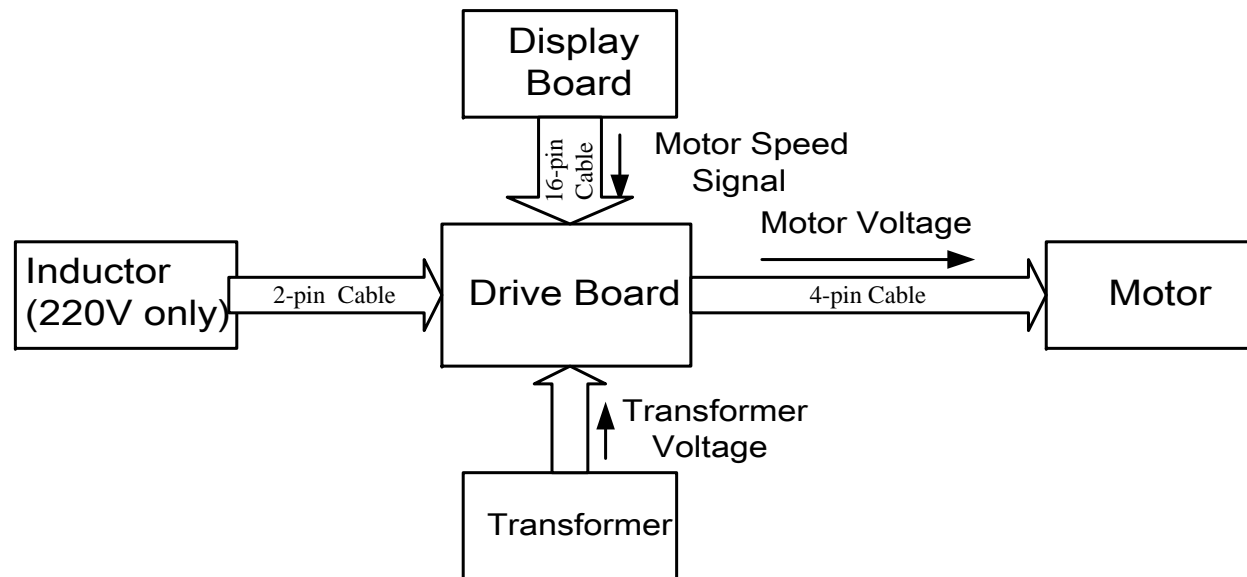

## SPORTS ART INDUSTRIAL CO., LTD.

### 1-3. Operation :

| Order | Component       | Troubleshooting  |
|-------|-----------------|--|
| 1     | Display         | 1. Press SPEED key; Display SPEED window shows “0.0”<br>2. The display board CPU sends the motor signal to the drive board, thereby controlling motor speed. |
| 2     | Inductor (220V) | 1. 220V units only<br>2. After inducting drive board AC voltage, the inductor sends VH voltage to the drive board motor circuit.                             |
| 3     | Transformer     | 1. Provides the motor drive circuit with all power.  |
| 4     | 16-pin cable    | Transfers display board signals to the drive board.  |
| 5     | Drive Board     | After processing the motor speed signal, the drive board provides power to the motor, making the motor operate.  |
| 6     | Motor           | Operates according to power from the drive board, making the motor turn, which makes the treadmill belt turn.  |

### 1-4. Error Message Simulation

| Order | Operation  |
|-------|--|
| 1     | Don't turn on the power. Remove motor M+, M- wire connections.                       |
| 2     | Turn on power. Press SPEED<▲> or <▼> key; display board shows “0.1”MPH or “0.2” KPH. |
| 3     | Motor doesn't rotate.  |
| 4     | “ERR:1” appears on the display.  |

### 1-5. Circumstances of Malfunction

(1) Press SPEED<▲> or <▼> key; the treadmill belt doesn't move; “ERR:1” appears on the display.

## SPORTS ART INDUSTRIAL CO., LTD.

### 1-6. Troubleshooting

| Order | Component     | Troubleshooting   |
|-------|---------------|---|
| 1     | Display Board | <ol style="list-style-type: none"> <li>1. Press firmly on the display board program IC.</li> <li>2. Inspect the 16-pin cable connections.</li> </ol>  |
| 2     | 16-pin cable  | <ol style="list-style-type: none"> <li>1. Test the cable by replacing it and seeing if that helps.</li> </ol>   |
| 3     | Inductor      | <ol style="list-style-type: none"> <li>1. Reconnect inductor wiring.</li> </ol>   |
| 4     | Transformer   | <ol style="list-style-type: none"> <li>1. Inspect the transformer wiring connections.</li> <li>2. Test transformer voltage.</li> </ol>  |
| 5     | Drive Board   | <ol style="list-style-type: none"> <li>1. Inspect the drive board wire connections.</li> <li>2. Place multi-meter probes on the drive board M+,M- ends; press the SPEED key; there should be some voltage.</li> <li>3. If there is no voltage, the drive board is bad or the display board signal, which travels the 16-pin cable, is in question.</li> </ol> |
| 6     | Motor         | <ol style="list-style-type: none"> <li>1. If the drive board motor voltage is OK and the motor doesn't operate, the motor is bad.</li> <li>2. Inspect the motor M+, M- terminals for a broken circuit.</li> <li>3. Inspect the motor wire connections.</li> <li>4. Inspect the motor brushes.</li> </ol>  |

# SPORTS ART INDUSTRIAL CO., LTD.

## 3. Reason for ERR1

### 2. Motor operates; ERR1 appears

#### 2-1. Explanation :

The motor operates; the optic sensor signal didn't reach the display board CPU; ERR 1 appears.

#### 2-1. Configuration

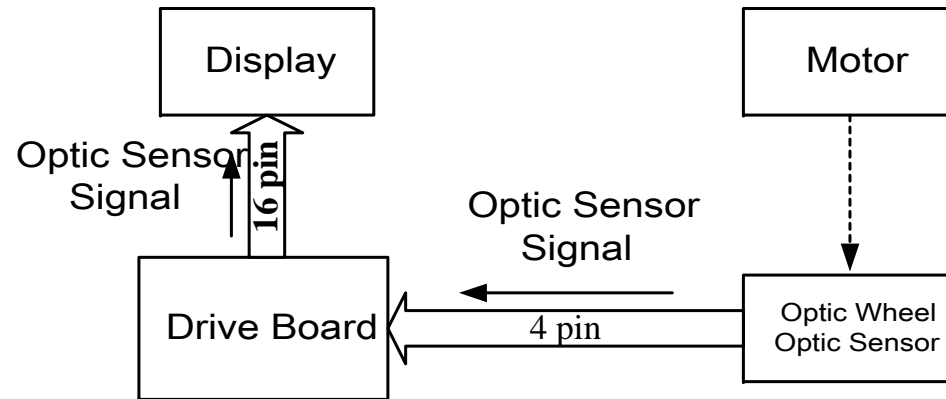



## SPORTS ART INDUSTRIAL CO., LTD.

### 2-3. Operation

| Order | Component                 | Troubleshooting  |
|-------|---------------------------|--|
| 1     | Motor                     | 1. The motor operates after the SPEED key is pressed.  |
| 2     | Tachometer & Optic Sensor | 1. Motor operation rotates the tachometer.<br>2. The optic sensor senses the tachometer rotation speed.  |
| 3     | 4-pin Cable               | 1. The optic sensor signal travels the 4-pin cable to the display board.   |
| 4     | Drive Board               | 1. After processing the optic sensor signal, the drive board CLK indicator lights.<br>2. The drive board sends the optic sensor signal to the display board.   |
| 5     | 16-pin Cable              | The optic sensor signal travels the 16-pin cable to the display board.   |
| 6     | Display Board             | 1. The CPU reads the optic sensor signal and emits the motor speed signal.<br>2. If the CPU doesn't read the optic sensor signal, the ERR1 message appears and the motor speed signal isn't sent to the drive board. |

### 2-4. Error Message Simulation

| Order | Operation   |
|-------|---|
| 1     | Don't turn on power. Remove optic sensor wire connections.                                |
| 2     | Turn on power. Press SPEED<▲> or <▼> key. The display board shows "0.1" MPH or "0.2" KPH. |
| 3     | Motor speed surges.   |
| 4     | Drive board CLK indicator doesn't light.  |
| 5     | Display board immediately shows "ERR:1." Motor stops operating.                           |

## SPORTS ART INDUSTRIAL CO., LTD.

### 2-5. Circumstance of Malfunction

- (1) Press SPEED <▲> or <▼> key; motor speed surges; display shows “ERR:1”.
- (2) Press SPEED <▲> or <▼> key; motor operates; display shows “ERR1:1”.

### 2-6. Troubleshooting

| Order | Component                  | Troubleshooting   |
|-------|----------------------------|---|
| 1     | Motor                      | 1. After pressing the SPEED key, inspect whether the motor rotates.   |
| 2     | Optic Wheel & Optic Sensor | 1. Inspect whether the optic wheel is fastened securely and placed in the center of the optic sensor.<br>2. Inspect whether the optic wheel teeth are broken or bent.<br>3. Inspect whether the optic sensor has been hit or damaged.<br>4. Inspect the optic sensor output: When rotating, the drive board CLK indicator flashes or remains lit. |
| 3     | Optic Sensor Cable (4PIN)  | 1. Test the optic sensor wire for continuity.<br>2. Test by replacing the optic sensor 4-pin cable.   |
| 4     | Drive Board                | 1. Check the CLK light: When the motor rotates, the CLK indicator flashes or remains lit.<br>2. Inspect the 16-pin cable and optic sensor cable connections.  |
| 5     | 16-pin Cable               | 1. Test by replacing the 16-pin cable with one known to work properly.  |
| 6     | Display Board              | 1. Inspect the 16-pin cable connection.<br>2. Press firmly on the motor program IC.   |

## 6100/E/6150/E Error Message Definition: ERR 3

1. Definition : The optic sensor speed signal and the speed setting differ too much, so ERR3 appears.

### 2. Configuration

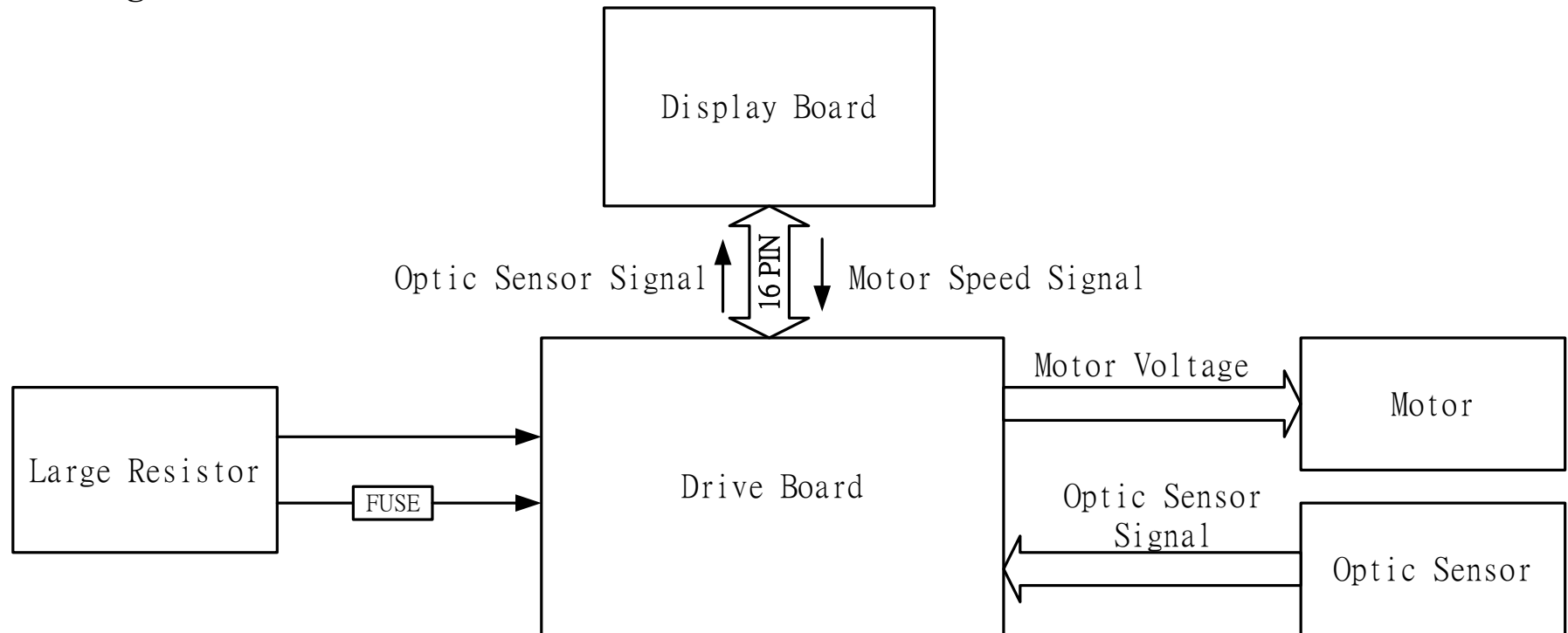

# SPORTS ART INDUSTRIAL CO., LTD.

## 3. Reason for ERR3

### 1. Receiving an ERR3 message when the incline is high

#### 1-1. Explanation

- (1) When the incline is at or above 7%, the walk board slope is steep, and the walk belt builds up momentum. Walk belt speed increases. The optic sensor detects the speed increase.
- (2) Detecting the faster optic sensor speed, the drive board produces resistance, making the belt speed return to normal.
- (3) If the drive board resistance doesn't take effect, the treadmill belt speeds up, and the display shows ERR3.

#### 2-1. Configuration

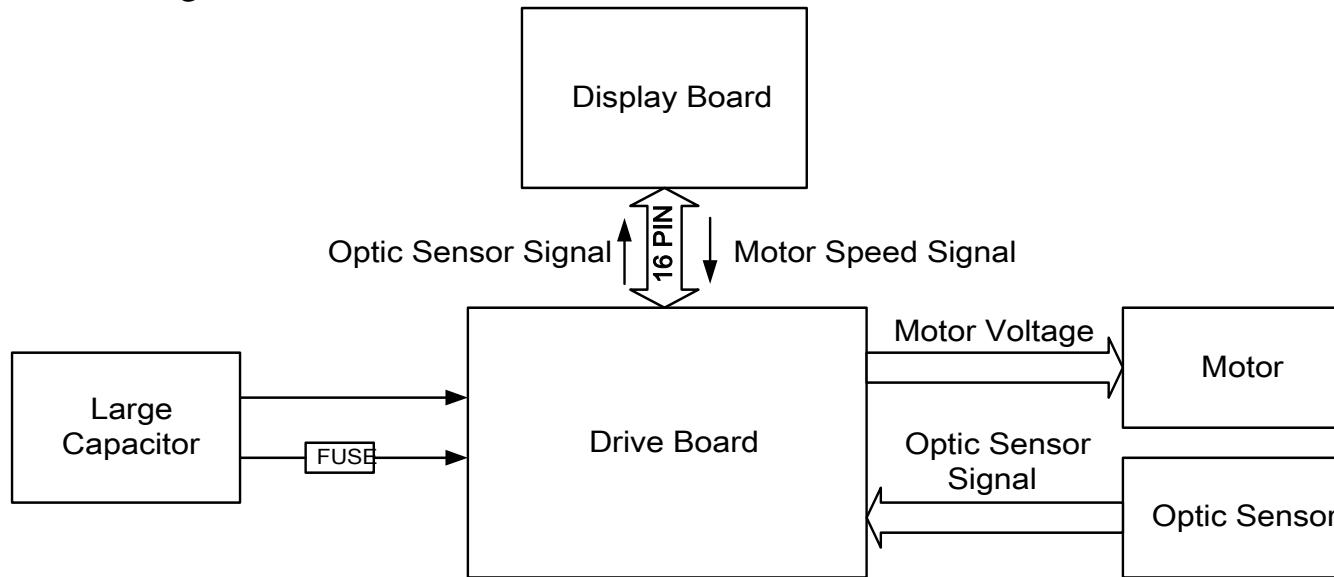

## SPORTS ART INDUSTRIAL CO., LTD.

### 1-3. Operation

| Order | Part          | Troubleshooting  |
|-------|---------------|--|
| 1     | Display       | 1. Display CPU emits the motor signal to the drive board, thus controlling motor speed.  |
| 2     | 16-pin Cable  | 1. Display signal travels the 16-pin cable to the drive board.   |
| 3     | Drive Board   | 1. After processing the motor signal, the drive board emits voltage to the motor, making the motor rotate.<br>2. If the motor speed quickens because of momentum (the optic sensor signal speeds up), the resistance circuit operates, making the motor speed slow down. |
| 4     | Resistor      | 1. The drive board resistance circuit operates through the resistor to produce motor resistance.   |
| 5     | Motor         | 1. The motor operates according to the drive board voltage emission, causing treadmill belt rotation.<br>2. Drive board resistance circuit operation makes the walk belt speed slow down.  |
| 6     | Optic Sensor  | 1. The optic sensor sends its signal, detected from the tachometer wheel movement, to the drive board.   |
| 7     | Drive Board   | 1. The drive board processes the optic sensor signal and its CLK indicator lights.   |
| 8     | 16-pin Cable  | 1. The drive board sends the optic sensor signal to the display board through the 16-pin cable.  |
| 9     | Display Board | 1. The CPU reads the optic sensor signal.<br>2. If the optic sensor signal and the actual speed differ too much, ERR3 appears.   |

### 1-4. Error Message Simulation

| Order | Operation   |
|-------|---|
| 1     | Don't turn on the power. Remove the large resistor wires on the drive board.              |
| 2     | Turn on the power. Press INCLINE<▲> key to 15%; the incline operates to the 15% position. |
| 3     | Press the SPEED key; the motor starts operating.  |
| 4     | Run on the walk belt.   |
| 5     | The display board immediately shows ERR3.   |

## SPORTS ART INDUSTRIAL CO., LTD.

### 1-5. Circumstance of the Error

- (1) Press SPEED<▲> key; after the motor operates, run on the walk belt; speed increases; “ERR3” appears.

### 1-6. Troubleshooting

| Order | Part           | Troubleshooting  |
|-------|----------------|--|
| 1     | Large Resistor | 1. Inspect the large capacitor fuse. 220V units: 5A; 110V units: 10A.<br>2. Inspect the drive board R, R connections.<br>3. Test whether the large resistor circuit is broken. 220V units: 5 Ohms; 110V units: 1.5 Ohms. |
| 2     | Drive Board    | 1. Replace the drive board.  |

# SPORTS ART INDUSTRIAL CO., LTD.

## 3. Reason for ERR3

### 2. After the motor operates, ERR3 immediately appears.

#### 2-1.

- (1) After the order operates, the optic sensor signal goes to the display board; the CPU reads the motor signal.
- (2) If the optic sensor signal and the SPEED window signal differ too much, ERR3 appears.

#### 2-1. Configuration

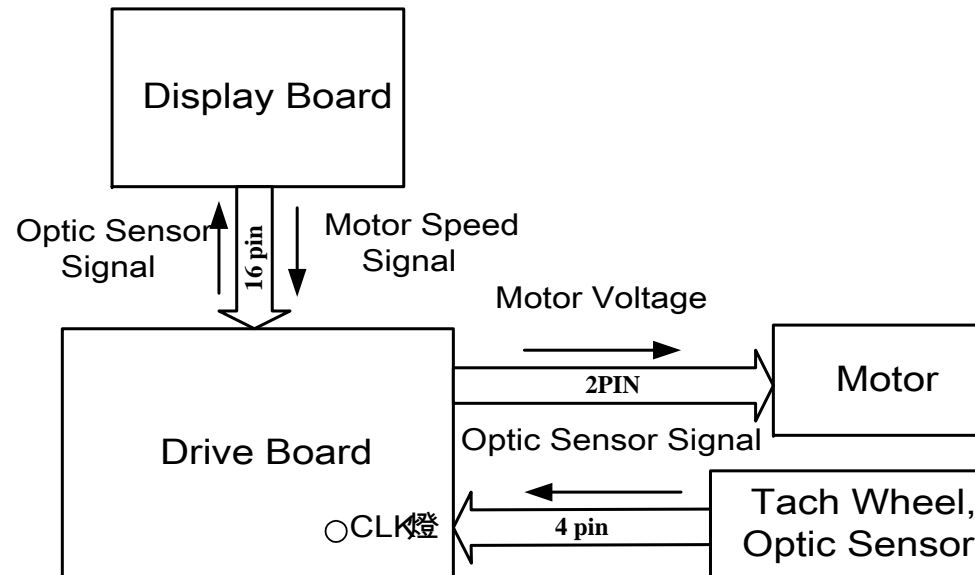

## SPORTS ART INDUSTRIAL CO., LTD.

### 2-3. Operation

| Order | Part               | Troubleshooting   |
|-------|--------------------|---|
| 1     | Display Board      | 1. The motor speed signal is sent to the drive board.   |
| 2     | Drive Board        | 1. The drive board supplies voltage for the motor.<br>2. After the optic sensor signal arrives at the drive board, the drive board adjusts power output.                          |
| 3     | Motor              | 1. The motor operates according to the drive board motor voltage.   |
| 4     | Optic Sensor       | 1. Once the tachometer wheel rotates, the optic sensor transmits its signal to the drive board.   |
| 5     | Optic Sensor Cable | 1. The optic sensor signal travels the optic sensor cable to the drive board.   |
| 6     | Drive Board        | 1. After processing the drive board signal, the drive board CLK indicator lights.<br>2. The drive board adjusts voltage output to the motor according to the optic sensor signal. |
| 7     | 16-pin Cable       | 1. The optic sensor signal travels the 16-pin cable to the display board.   |
| 6     | Display Board      | 1. The CPU reads the optic sensor signal and emits a motor speed signal.<br>2. If the CPU optic sensor signal and SPEED window speed setting differ too much, ERR3 appears.       |

### 2-4. Error Message Simulation

| Order | Operation  |
|-------|--|
| 1     | Turn on power; Press SPEED<▲> key; Display shows “0.1” MPH or “0.2” KPH. |
| 2     | The treadmill belt speeds up.  |
| 3     | Drive board CLK indicator flashes or remains lit.                        |
| 4     | The display board immediately shows “ERR3”; motor stops operating.       |



## SPORTS ART INDUSTRIAL CO., LTD.

### 2-5. Circumstance of Error

- (1) Press SPEED<▲> key; Don't stand on the treadmill; Display immediately shows "ERR3".
- (2) Press SPEED<▲> key; The treadmill belt moves; Display immediately shows "ERR3".

### 2-6. Troubleshooting

| Order | Part                         | Troubleshooting   |
|-------|------------------------------|---|
| 1     | Display Board                | 1. Press firmly on the motor program.<br>2. Inspect the 16-pin cable connection.<br>3. Replace the motor program IC with a new motor program IC.  |
| 2     | Optic Wheel;<br>Optic Sensor | 1. Inspect whether the optic wheel fastened tightly and rotates in the middle of the optic sensor.<br>2. Inspect whether the optic wheel teeth are missing.<br>3. Replace optic sensor. |
| 3     | Motor                        | 1. Inspect the motor or test it by replacing it with another.   |
| 4     | Drive Board                  | 1. Inspect the 16-pin cable connections; Inspect the optic sensor cable connections.<br>2. Test the drive board by replacing it.  |

**3. Reason for ERR 3**

**3. While the motor is in operation, ERR 3 appears occasionally.**

3-1. Explanation :

- (1) After the motor moves, the optic sensor sends its signal to the display board, and the CPU reads the signal.
- (2) If the optic sensor signal and SPEED window signal differ too much, ERR3 appears.
- (3) If the CPU receives environmental interference and cannot read the optic sensor signal, ERR3 appears.

3-2. Configuration

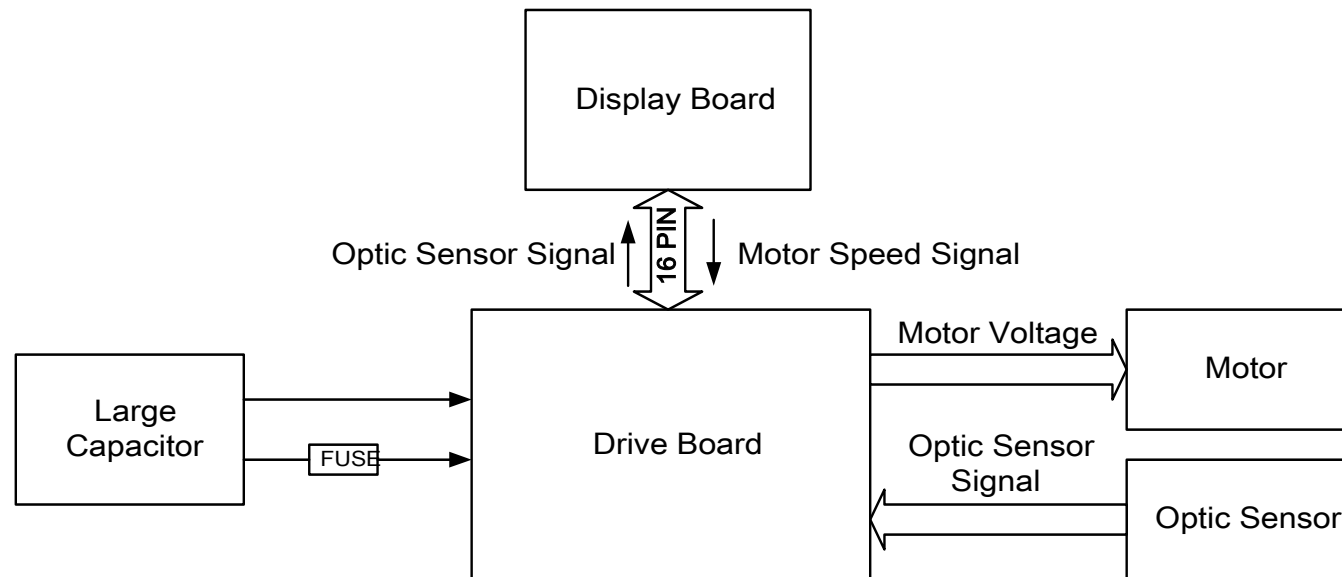

## SPORTS ART INDUSTRIAL CO., LTD.

### 3-3. Operation

| Order | Part               | Troubleshooting   |
|-------|--------------------|---|
| 1     | Display Board      | 1. The motor speed signal is sent to the drive board.   |
| 2     | Drive Board        | 1. The drive board supplies voltage for the motor.<br>2. After the optic sensor signal arrives at the drive board, the drive board adjusts power output.                          |
| 3     | Motor              | 1. The motor operates according to the drive board motor voltage.   |
| 4     | Optic Sensor       | 1. Once the optic wheel rotates, the optic sensor transmits its signal to the drive board.  |
| 5     | Optic Sensor Cable | 1. The optic sensor signal travels the optic sensor cable to the drive board.   |
| 6     | Drive Board        | 1. After processing the drive board signal, the drive board CLK indicator lights.<br>2. The drive board adjusts voltage output to the motor according to the optic sensor signal. |
| 7     | 16-pin Cable       | 1. The optic sensor signal travels the 16-pin cable to the display board.   |
| 6     | Display Board      | 1. The CPU reads the optic sensor signal and emits a motor speed signal.<br>2. If the CPU optic sensor signal and SPEED window speed setting differ too much, ERR3 appears.       |

### 3-4. Error Message Simulation

| Order | Operation  |
|-------|--|
| 1     | Turn on the power; Press SPEED<▲> or<▼> key; Display shows “0.1” MPH or “0.2” KPH. |
| 2     | Walk on the walk belt; Pull the belt speed faster than the setting speed.          |
| 3     | Drive board CLK indicator flashes or remains lit.                                  |
| 4     | Display board immediately shows “ERR3”; Motor stops operating.                     |

## SPORTS ART INDUSTRIAL CO., LTD.

### 3-5. Circumstance of Malfunction

(1) Press SPEED <▲> key. Motor operates for some time. Then ERR3 appears on the display.

### 3-6. Troubleshooting

| Order | Part                        | Troubleshooting  |
|-------|-----------------------------|--|
| 1     | Display Board               | 1. Reinsert motor IC.<br>2. Inspect the 16-pin cable and its connections.<br>3. Replace motor program with one of a newer version.   |
| 2     | Optic Wheel<br>Optic Sensor | 1. Inspect whether the optic wheel is screwed in securely and rotating in the middle of the optic sensor.<br>2. Test the optic sensor by replacing it with another and checking whether the problem is resolved. |

## 6100/E/6150/E Error Message : ERR 6

### 1. Definition

In the midst of incline action, the display board CPU didn't read the VR value, so ERR6 appears.

### 2. Configuration

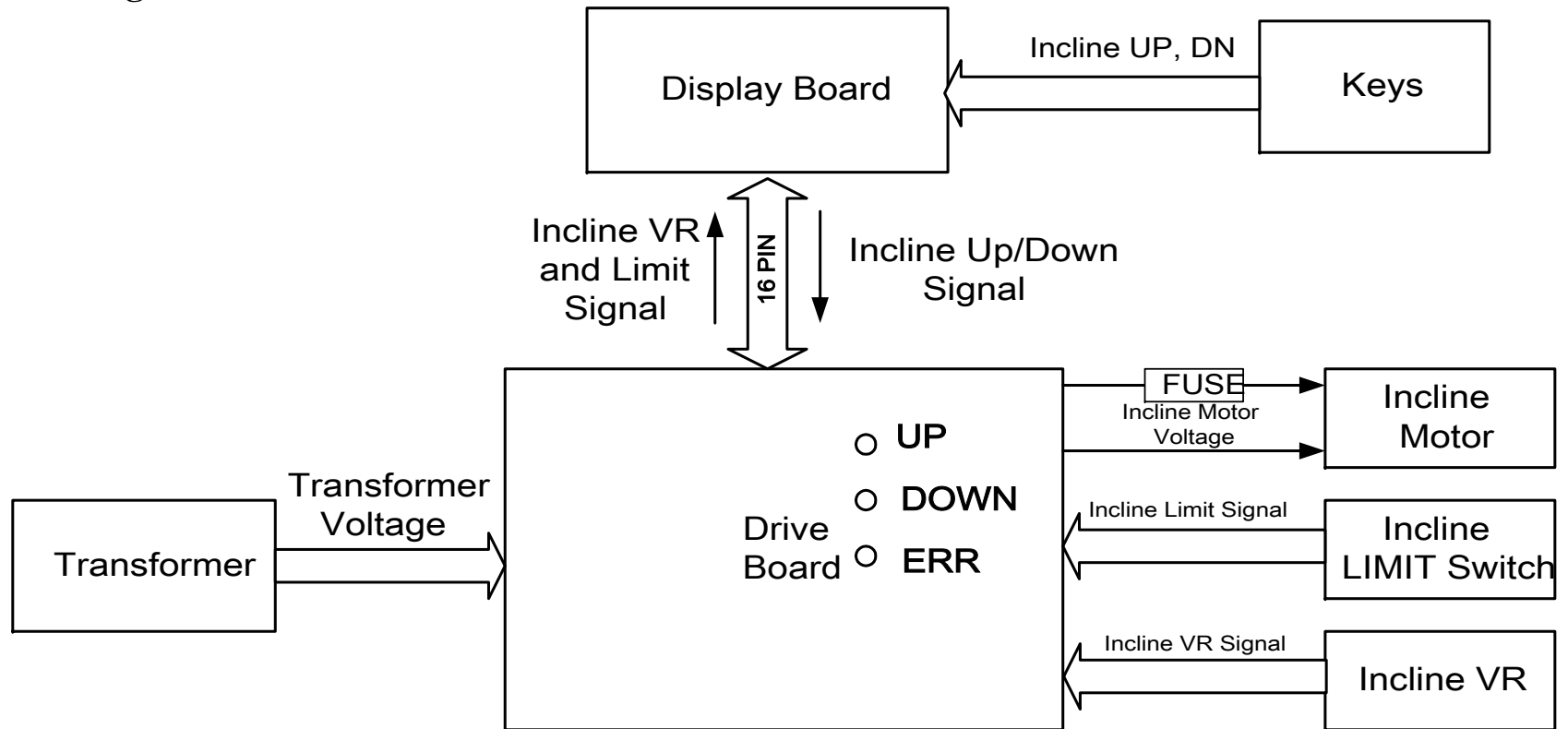

**3. Reason for ERR6**

**1. Press incline up/down key; incline doesn't operate; ERR6 appears.**

1-1. (1) Press incline up or down keys; Drive board UP or DN indicator lights; Incline up/down operates; The incline VR value changes.

(2) The display board CPU reads the incline VR value. If there's no voltage variation, the incline motor isn't operating; ERR6 appears.

2-1. Configuration

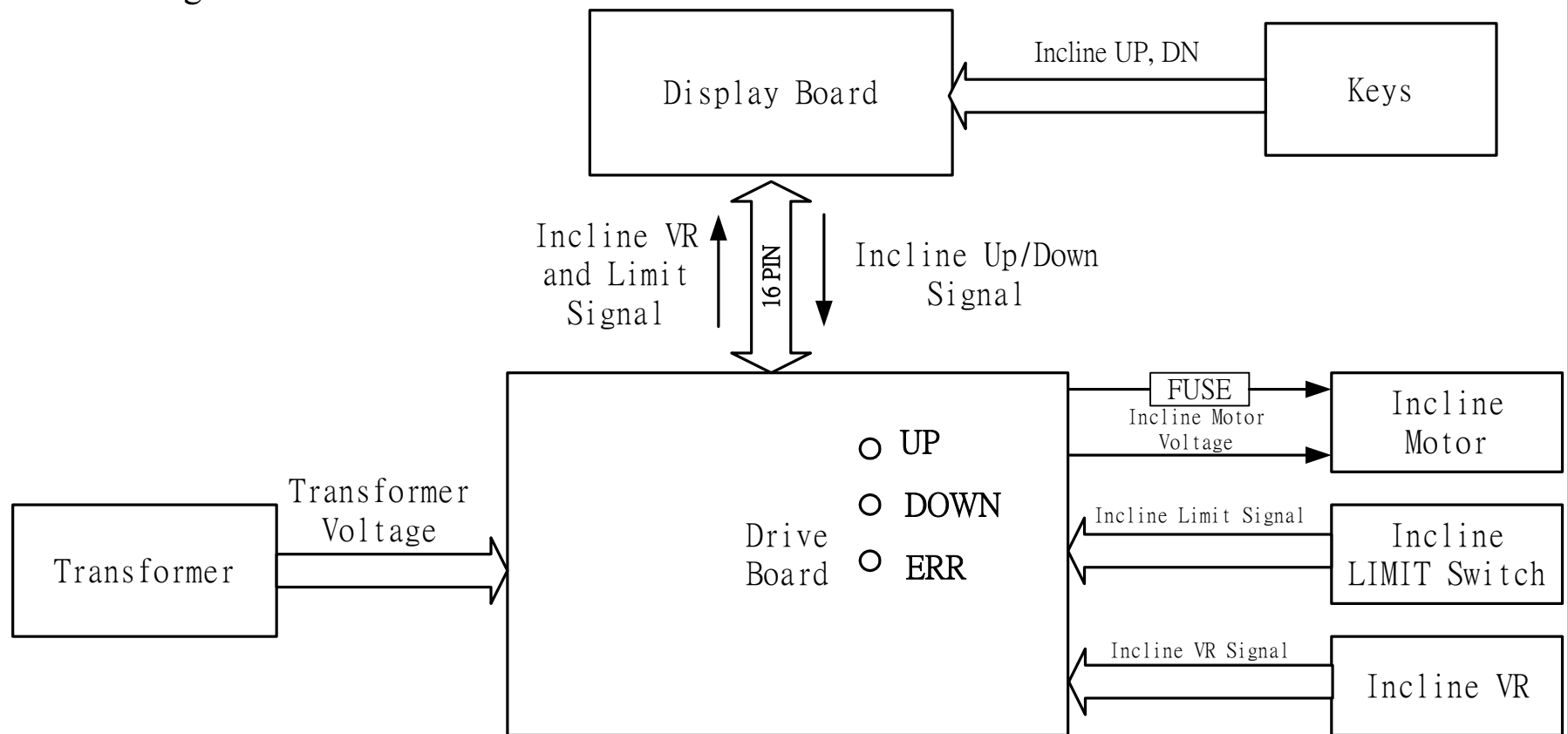

# SPORTS ART INDUSTRIAL CO., LTD.

## 1-3. Operation

| Order | Part                  | Operation  |
|-------|-----------------------|--|
| 1     | Display Board         | 1. Press INCL<▲> or INCL<▼> key; Incline window shows incline value.<br>2. CPU sends the incline up/down signal to the drive board.  |
| 2     | 16-pin Cable          | 1. The display incline signal travels the 16-pin cable to the drive board.   |
| 3     | Transformer           | 1. The transformer provides power to the drive board incline motor circuit.  |
| 4     | Drive Board (ERR LED) | 1. Press INCL<▲> key; Drive board UP LED lights; Press INCL<▼> key; the drive board DN LED lights.<br>2. When the UP LED lights, the drive board drive circuit emits positive voltage, making for up incline action.<br>3. When the DN LED lights, the drive board drive circuit emits negative voltage, making for down incline action. |
| 6     | Incline Motor         | 1. When the drive board UP LED lights, the incline motor operates up.<br>2. When the drive board DN LED lights, the incline motor operates down.   |

## 1-4. Error Message Simulation

| Order | Operation  |
|-------|--|
| 1     | Don't turn on power. Remove the incline fuse.      |
| 2     | Turn on power. Press INCLINE<▲> or INCLINE<▼> key. |
| 3     | Drive board UP or DN indicator lights.             |
| 4     | Incline doesn't operate.                           |
| 5     | Display board shows ERR6.                          |

## 1-5. Circumstances of the Malfunction

- (1) Press INCLINE<▲> key; Incline motor doesn't operate; Display immediately shows ERR6.
- (2) Press INCLINE<▼> key; Incline motor doesn't operate; Display immediately shows ERR6.

## SPORTS ART INDUSTRIAL CO., LTD.

(3) Press INCLINE<▲> or <▼> key; The incline sounds strange; ERR6 appears.

(4) Press INCLINE<▲> or <▼> key; The incline fuse breaks, ERR6 appears.

### 1-6. Troubleshooting

| Order | Part                                  | Troubleshooting   |
|-------|---------------------------------------|---|
| 1     | Display Board                         | <ol style="list-style-type: none"> <li>1. Press incline &lt;▲&gt; key; Drive board UP indicator lights.</li> <li>2. Press incline &lt;▼&gt; key; Drive board DN indicator lights.</li> <li>3. If not as above, press down on the display CPU or inspect the cable.</li> </ol> |
| 2     | 16-pin Cable                          | <ol style="list-style-type: none"> <li>1. Inspect the 16-PIN cable connection.</li> <li>2. Test the cable by replacing it.</li> </ol>   |
| 3     | Transformer                           | <ol style="list-style-type: none"> <li>1. Inspect whether the transformer voltage (orange) is AC 27V.</li> </ol>  |
| 4     | Drive Board<br>(ERR lights)           | <ol style="list-style-type: none"> <li>1. Inspect whether the ERR indicator is lit.</li> <li>2. Press incline up or down key to make the incline return to normal position.</li> <li>3. If ERR6 still appears, adjust the incline VR set to base level.</li> </ol>            |
| 5     | Drive Board<br>(ERR doesn't<br>light) | <ol style="list-style-type: none"> <li>1. Press INCL&lt;▲&gt;/&lt;▼&gt; key; Inspect whether the drive board UP/DN indicator lights.</li> <li>2. When the drive board UP or DN indicator lights, test the incline motor terminals for voltage.</li> </ol>                     |
| 6     | Incline Fuse                          | <ol style="list-style-type: none"> <li>1. Inspect whether the fuse is broken; Replace it if broken.</li> </ol>  |
| 7     | Incline Motor                         | <ol style="list-style-type: none"> <li>1. Inspect whether the incline motor is stuck.</li> <li>2. Inspect whether the incline motor gear is broken.</li> <li>3. Test whether the incline motor circuit is broken.</li> <li>4. Readjust the incline VR.</li> </ol>             |



**3. Reasons for ERR6**

**1. Press the Incline Up/Down key; Incline operates, ERR6 appears.**

1-1. Explanation :

- (1) Press incline up or down key; After incline operates, the incline VR value signal is sent to the display board.
- (2) Display board CPU reads the incline VR value. If the VR value and the setting value differ, ERR6 appears.

2-1. Configuration

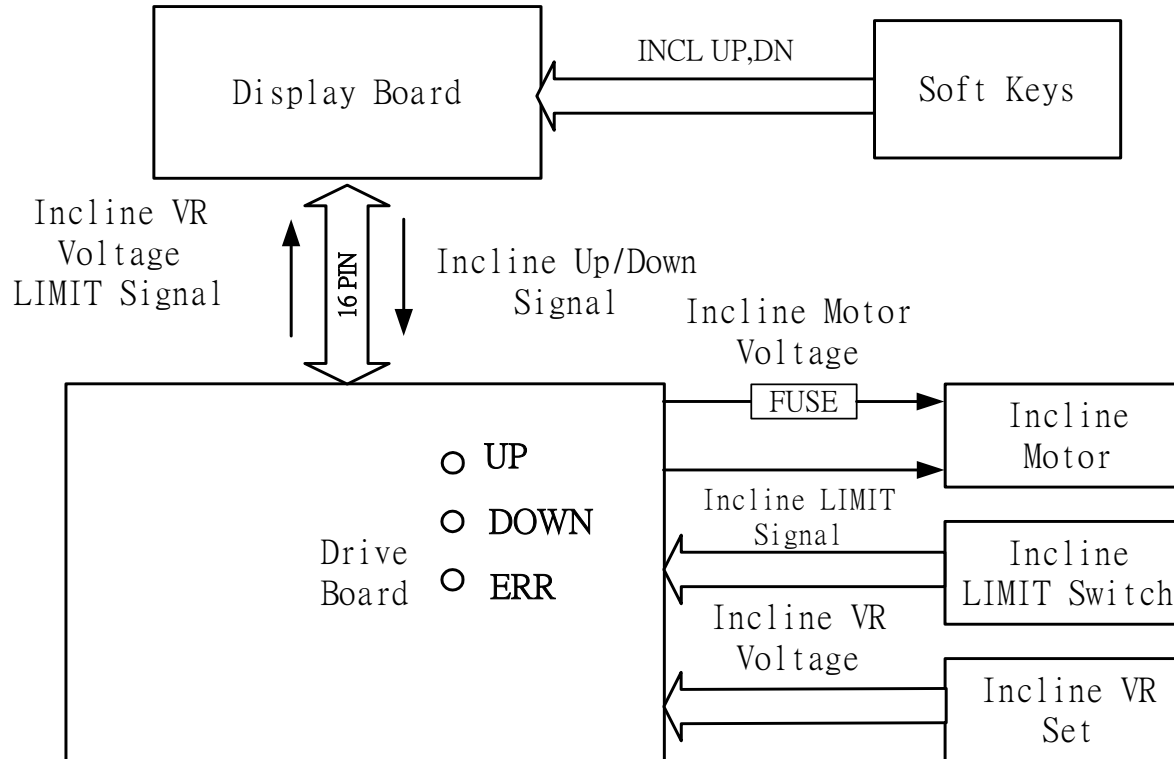

## SPORTS ART INDUSTRIAL CO., LTD.

### 1-3. Operation

| Order | Part                        | Operation  |
|-------|-----------------------------|--|
| 1     | Display Board               | 1. Press INCL<▲> or INCL<▼> key; The incline window shows the incline value.<br>2. The CPU sends the incline up/down signal to the drive board.  |
| 2     | 16-pin Cable                | 1. The display board incline signal travels the 16-pin cable to the drive board.   |
| 3     | Drive Board<br>(ERR lights) | 1. Press INCL<▲> key; Drive board UP indicator lights; Press INCL<▼> key; Drive board DN indicator lights.<br>2. When the UP indicator lights, the drive board drive circuit emits positive voltage, making the incline operate up.<br>3. When the DN indicator lights, the drive board drive circuit emits negative voltage, making the incline operate down. |
| 4     | Incline Motor               | 1. When the drive board UP indicator lights, the incline motor operates up.<br>2. When the drive board DN indicator lights, the incline motor operates down.   |
| 5     | Incline LIMIT               | 1. When the LIMIT switch operates, the drive board ERR indicator lights; When the LIMIT switch doesn't operate, the drive board ERR indicator doesn't light.<br>2. When the incline is from 0-15%, the indicator normally doesn't light. If it does light, the incline range has been exceeded. Adjust the incline set.  |
| 6     | Incline VR                  | 1. Incline up or down action makes the VR value change.<br>2. At 0% incline, the VR value voltage is 3.55V (green-blue wire).  |
| 7     | Drive Board                 | 1. The drive board sends the incline VR value to the display board.  |
| 8     | 16-pin Cable                | 1. The incline VR value travels the 16-pin cable from the drive board to the display board.  |
| 9     | Display Board               | 1. The CPU reads the VR value. At 0% incline, the VR voltage is 3.55V; At 15% incline, the voltage is 1.20V.   |

### 1-4. Error Message Simulation

| Order | Operation  |
|-------|--|
| 1     | Remove the incline VR set without tightening down the incline set. |
| 2     | Turn on the power. Press INCLINE<▲> or INCLINE<▼> key.             |
| 3     | Drive board UP or DN indicator lights.                             |
| 4     | Incline operates up or down.                                       |
| 5     | ERR6 immediately appears.  |

## SPORTS ART INDUSTRIAL CO., LTD.

### 1-5. Circumstance of Malfunction

- (1) Press INCLINE<▲> key; Incline motor operates halfway; ERR6 appears.
- (2) Press INCLINE<▼> key; Incline motor operates halfway; ERR6 appears.

### 1-6. Troubleshooting

| Order | Part                 | Troubleshooting  |
|-------|----------------------|--|
| 1     | Display Board        | <ol style="list-style-type: none"> <li>1. Press on the main program.</li> <li>2. Inspect the 16-PIN cable connection.</li> </ol>   |
| 2     | 16-pin Cable         | <ol style="list-style-type: none"> <li>1. Test by replacing the 16-pin cable.</li> </ol>   |
| 3     | Drive Board          | <ol style="list-style-type: none"> <li>1. Press display INCL&lt;▲&gt;/&lt;▼&gt; key; Inspect whether the drive board UP/DN indicator lights.</li> <li>2. When UP or DN indicators are lit, test whether incline motor terminals have voltage.</li> <li>3. If ERR indicator lights, adjust the incline set to the base position.</li> </ol> |
| 4     | Incline Motor        | <ol style="list-style-type: none"> <li>1. Inspect whether the incline motor is stuck.</li> <li>2. Inspect whether the incline motor internal gears are broken.</li> <li>3. Inspect whether the incline motor is broken.</li> </ol>   |
| 5     | Incline LIMIT Switch | <ol style="list-style-type: none"> <li>1. Inspect whether at 0-15% position the ERR indicator lights.</li> <li>2. If the ERR indicator lights at the 0-15% position, readjust the incline set to the base position.</li> </ol>   |
| 6     | Incline VR Set       | <ol style="list-style-type: none"> <li>1. Inspect the incline VR wire connection.</li> <li>2. Inspect whether the incline VR wire voltage at 0% = 3.55V; at 15% =1.20V.</li> </ol>   |
| 7     | Incline Fuse         | <ol style="list-style-type: none"> <li>1. Inspect whether the incline fuse has broken. Replace it if necessary.</li> </ol>   |
| 8     | Incline Motor        | <ol style="list-style-type: none"> <li>1. Inspect whether the incline motor is stuck.</li> <li>2. Inspect whether the incline gear is broken.</li> <li>3. Test whether the motor has a broken circuit.</li> <li>4. Readjust the incline VR and incline motor.</li> </ol>   |

## 6100/E/6150/E Error Message : ERR 7

1. Definition : The display board didn't sense the incline VR value or the value exceeds the normal range, so "ERR7" appears.

### 2. Configuration

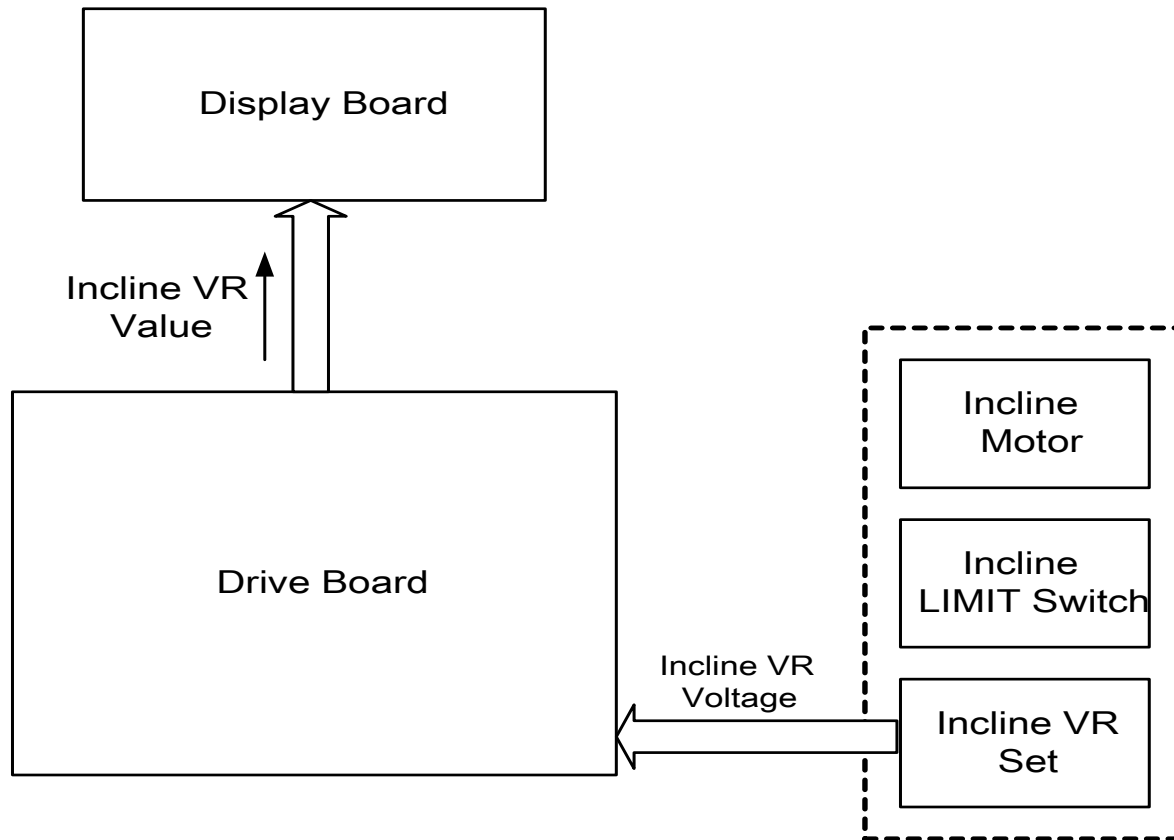

**3. Reason for ERR 7**

**1. Incline VR Value Exceeds Normal Range, so ERR7 appears.**

1-1. Explanation :

(1) The incline operation error makes the VR value exceed the range.

(2) After turning on unit, the display board detects the VR voltage exceeds the range; ERR7 appears.

1-2. Configuration

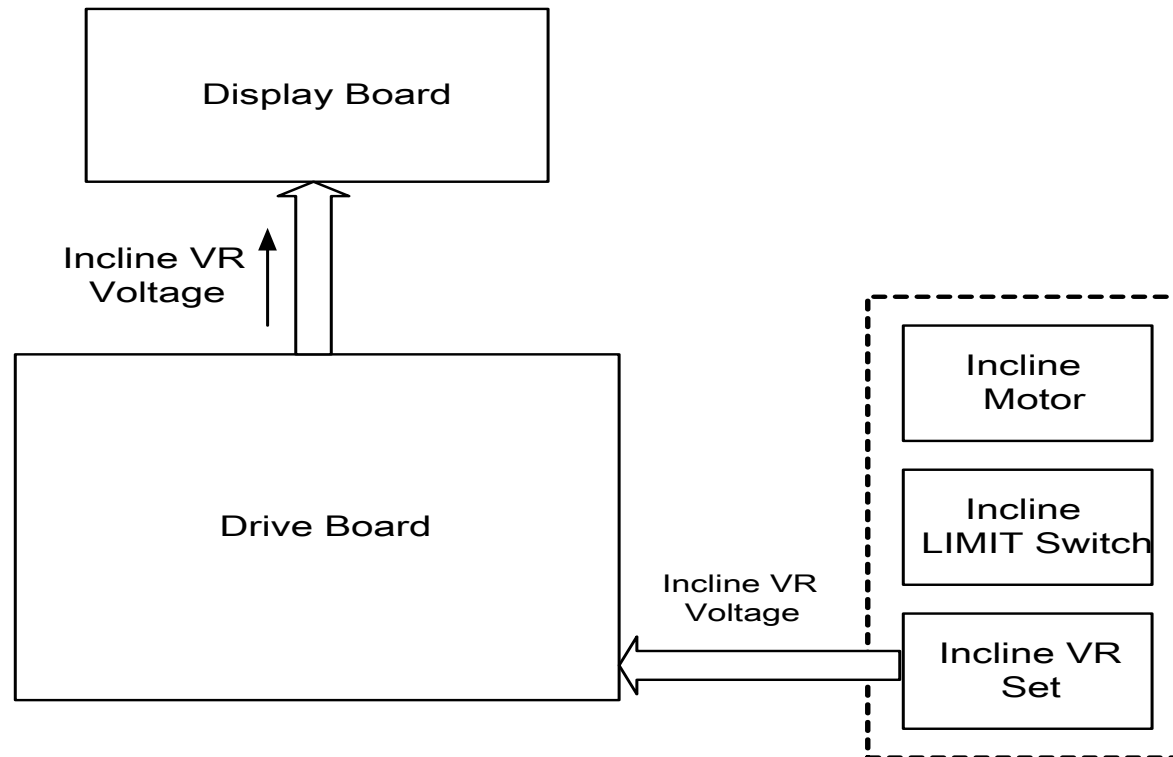

## SPORTS ART INDUSTRIAL CO., LTD.

### 1-3. Operation :

| Order | Part          | Operation  |
|-------|---------------|--|
| 1     | Incline VR    | 1. Incline operation changes the VR value.<br>2. The incline VR value travels the incline VR cable to the drive board.                         |
| 2     | Drive Board   | 1. The drive board sends the incline VR value to the display board.  |
| 3     | Display Board | 1. After turning on the unit, inspect the incline VR voltage.<br>2. If the VR voltage exceeds the normal range or is undetected, ERR7 appears. |

### 1-4. Error Message Simulation

| Order | Operation  |
|-------|--|
| 1     | Turn on power; Remove the drive board up incline wire. |
| 2     | Turn on the power.                                     |
| 3     | The display board shows "ERR7".                        |

### 1-5. Circumstances of the Malfunction

(1) Turn on power; ERR7 immediately appears on the display.

### 1-6. Troubleshooting

| Order | Part          | Troubleshooting   |
|-------|---------------|---|
| 1     | Incline VR    | 1. Test whether VR voltage exceeds the normal range.<br>2. If the VR value exceeds the normal range, readjust the incline motor and VR set to base level. |
| 2     | Display Board | 1. Replace the display board U12 and ADC0804.   |

## 2. VR Signal Circuit is Broken; ERR7 Appears

### 2-1. Explanation :

- (1) Incline VR signal is broken, so the display CPU doesn't detect the VR signal, so "ERR 7" appears.

### 2-2. Configuration

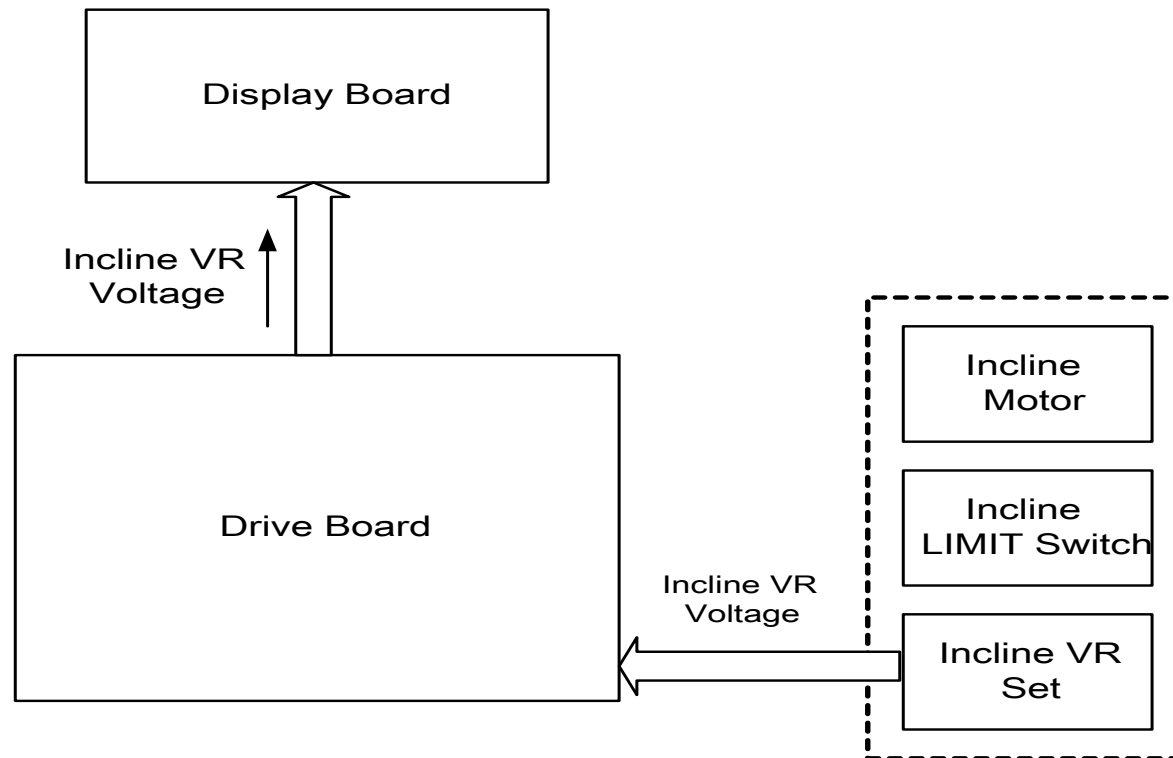

## SPORTS ART INDUSTRIAL CO., LTD.

### 2-3. Operation :

| Order | Part          | Operation   |
|-------|---------------|---|
| 1     | Incline VR    | 1. Incline operation changes the VR voltage value.<br>2. The incline VR value travels the incline VR cable to the drive board.                              |
| 2     | Drive Board   | 1. The drive board sends the incline VR value to the display board.   |
| 3     | Display Board | 1. After turning off the unit, inspect the incline VR voltage.<br>2. If the VR voltage exceeds the normal range or the value is not detected, ERR7 appears. |

### 2-4. Error Message Simulation

| Order | Operation  |
|-------|--|
| 1     | Don't turn on the power. Remove the drive board incline cable. |
| 2     | Turn on the power switch.                                      |
| 3     | "ERR7" appears on the display.                                 |

### 2-5. Circumstances of Malfunction

- (1) Turn on the power. ERR7 immediately appears on the display.



## SPORTS ART INDUSTRIAL CO., LTD.

### 2-6. Troubleshooting

| Order | Part          | Troubleshooting  |
|-------|---------------|--|
| 1     | Incline VR    | 1. Reconnect the incline VR cable.<br>2. Check whether the incline wire is broken.   |
| 2     | Drive Board   | 1. Inspect the incline cable and 16-pin cable connections.   |
| 3     | Cable         | 1. Inspect the cable connections.<br>2. Inspect whether the cable is broken or pinched.<br>3. Test by replacing the cable. |
| 4     | Display Board | 1. Inspect the 16-pin cable connections.<br>2. Press on the main program IC.<br>3. Replace U12 ADC0804.                    |

## 6100/E/6150/E Error Message : ERR 8

### 1. Definition :

Poor communication between display board CPUs causes ERR 8 to appear.

### 2. Configuration

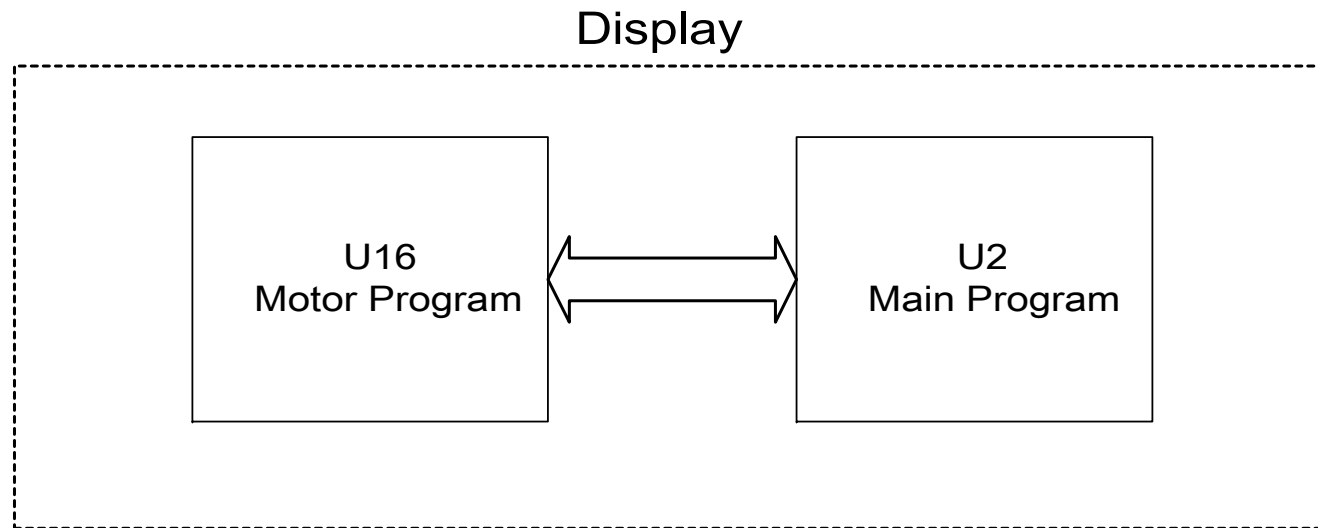

SPORTS ART INDUSTRIAL CO., LTD.

**3. Reason for ERR 8**

**1. Turn on unit; Display board immediately shows ERR 8.**

1-1. Explanation :

- (1) After turning on the power, display board U2 and U16 read off each other.
- (2) If they are unable to read material, ERR 8 appears.

1-2. Configuration

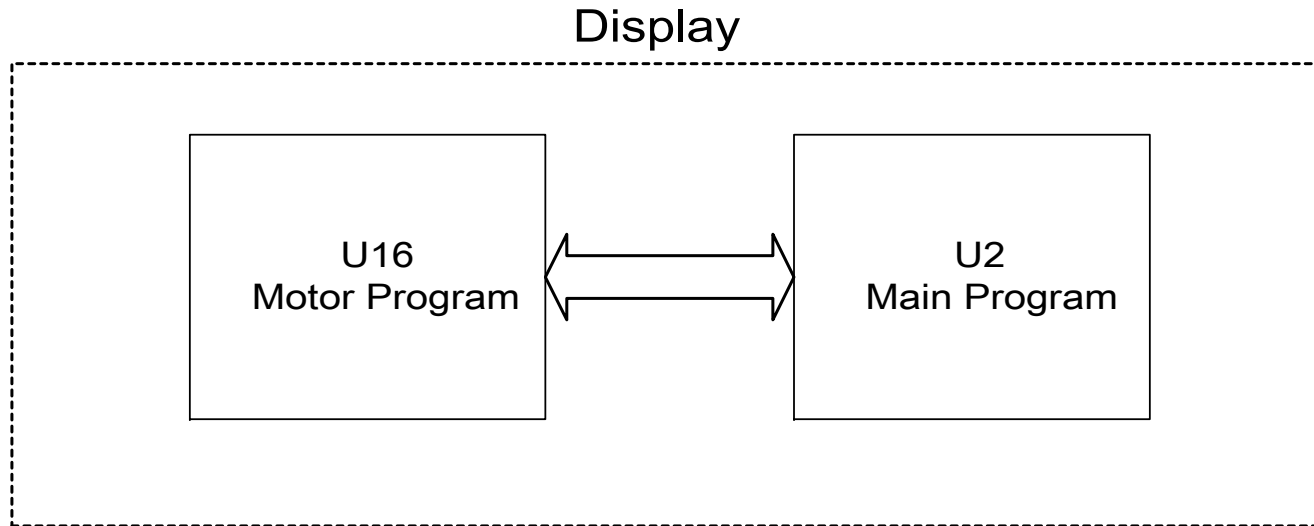

1-3. Operation

| Order | Part          | Operation   |
|-------|---------------|---|
| 1     | Display Board | 1. After turning on the unit, U2 sends its signal to U16; and U16 sends its signal to U2.<br>4. If unable to read U16, "ERR 8" appears. |

SPORTS ART INDUSTRIAL CO., LTD.

**3. Reason for ERR 8**

**1. Turn on unit; ERR 8 immediately appears on the display.**

1-1. Explanation :

- (1) After power is turned on, the display U2 and U16 components read off each other.
- (2) If unable to read material, ERR8 appears on the display.

1-2. Configuration

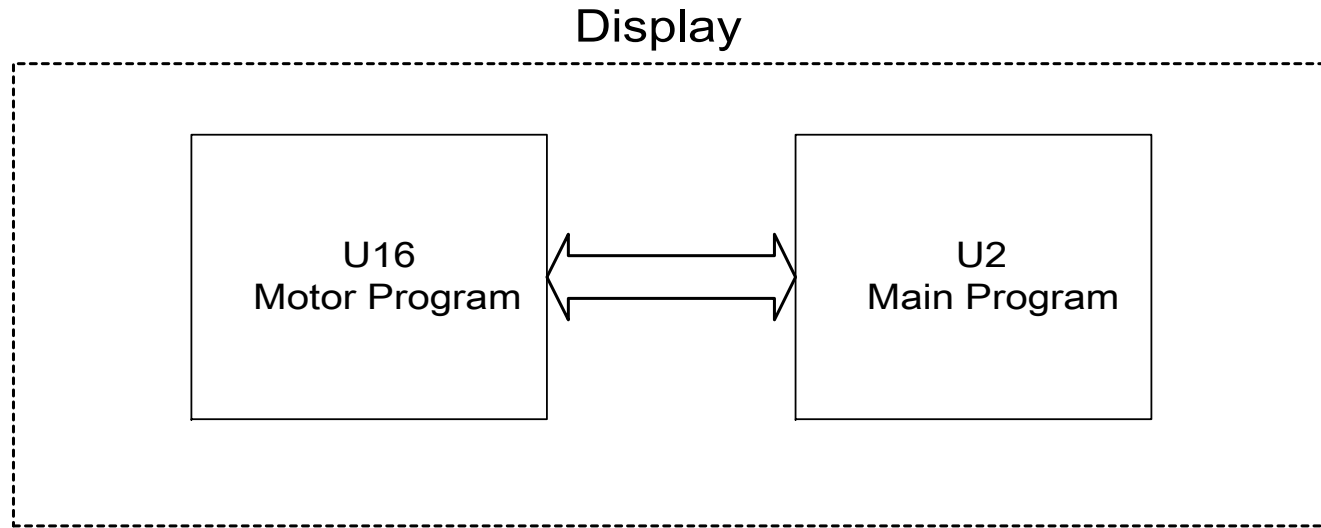

1-3. Operation

| Order | Part          | Operation   |
|-------|---------------|---|
| 1     | Display Board | 1. Turn on the unit. U2 sends its signal to U16; U16 sends information back to U2.<br>4. If unable to read U16, ERR8 appears. |

## SPORTS ART INDUSTRIAL CO., LTD.

### 1-4. Error Message Simulation

| Order | Operation   |
|-------|---|
| 1     | Don't turn on the power. Don't put the first pin of U16 into the U16IC. |
| 2     | Turn on power.  |
| 3     | Display shows "ERR8" and emits a beep sound.                            |

### 1-5. Circumstances of the Malfunction

(1) Turn on the power. The display beeps once and ERR 8 appears.

### 1-6. Troubleshooting

| Order | Part          | Troubleshooting  |
|-------|---------------|--|
| 1     | Display Board | <ol style="list-style-type: none"><li>1. Inspect whether the U16 program IC pins are in place and soldered well. Re-solder if necessary.</li><li>2. Check whether the U16 program IC pins are in place. Reinsert the IC.</li><li>3. Replace the U16 program IC ( motor program ) .</li></ol> |

SPORTS ART INDUSTRIAL CO., LTD.

**2. With the treadmill in operation, ERR8 appears.**

2-1. Explanation :

- (1) In operation, the display board U2 and U16 ICs read off each other.
- (2) If the ICs are unable to read material, ERR8 appears.
- (3) Often, if the unit grounding system is poor, there's too much interference for the CPU to get a clear signal.

2-2. Configuration

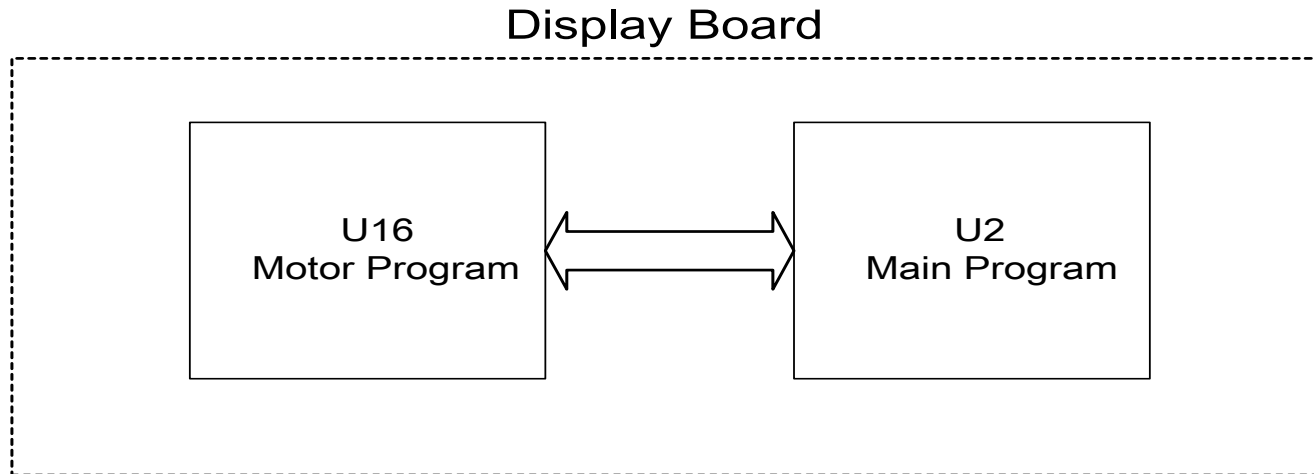

2-3. Operation

| Order | Part          | Operation  |
|-------|---------------|--|
| 1     | Display Board | <ul style="list-style-type: none"><li>1. When the motor operates, U2 sends its signal to the U16 motor program.</li><li>2. The U16 motor program information is sent to U2.</li><li>3. If U2 cannot read material or reads error material from U16, "ERR 8" appears.</li></ul> |

## SPORTS ART INDUSTRIAL CO., LTD.

### 2-4. Circumstances of Malfunction

(1) Press SPEED key; treadmill motor operates for a while, ERR 8 appears.

### 2-5. Troubleshooting

| Order | Part                          | Troubleshooting   |
|-------|-------------------------------|---|
| 1     | Display Board<br>(Program IC) | 1. A program revision 4-20-00 eliminated ERR8.<br>2. Replace program with one made after 4-20-00.                                   |
| 2     | Ground System                 | 1. The power input in the facility must have adequate grounding.<br>2. Inspect whether the unit is grounded to the facility ground. |

## 6100/E/6150/E Error Message : ERR 9

### 1. Definition

The treadmill operation distance exceeds its range.

### 2. Configuration

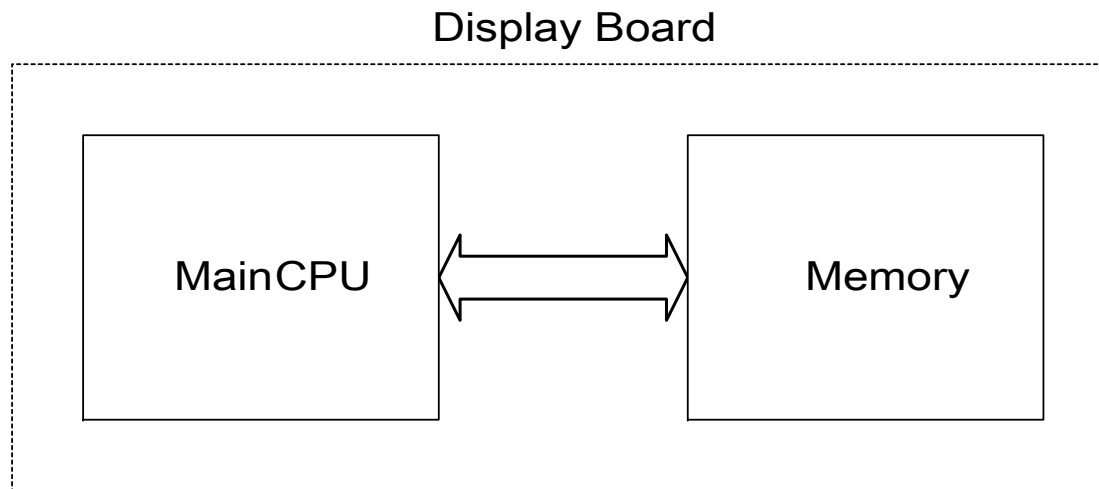



**3. Reason for ERR 9**

**1. As soon as the unit is turned on, ERR9 immediately appears.**

1-1. Explanation :

- (1) CPU stores the treadmill operation distance in the memory.
- (2) When the operation distance exceeds the memory capacity, the display shows ERR9.
- (3) When ERR 9 appears, clear the mileage from memory.

1-2. Configuration

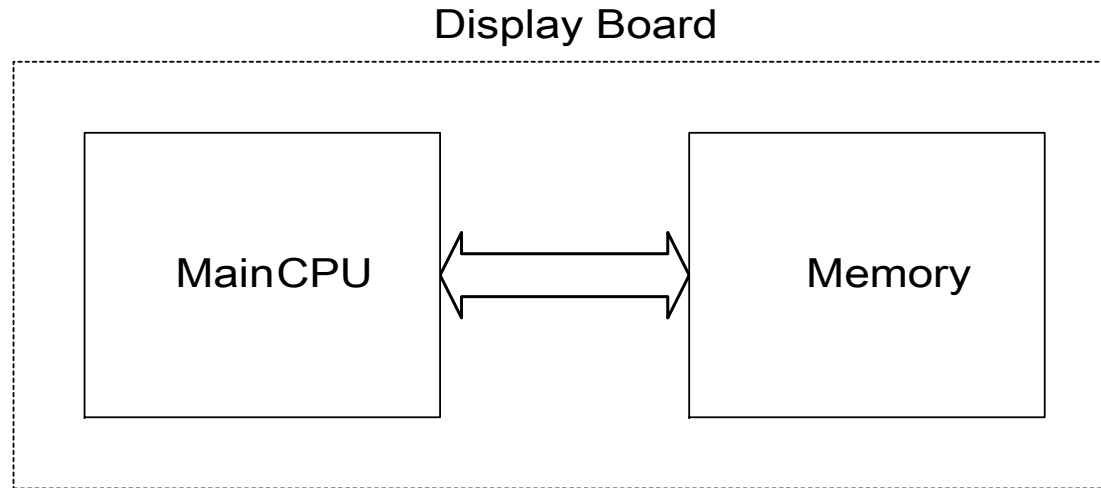

1-3. Operation

| Order | Part          | Operation  |
|-------|---------------|--|
| 1     | Display Board | 1. The CPU calculates the accruing operation DIST value and stores it in memory.<br>2. When the operating distance read by the CPU exceeds the memory, the display shows "ERR9". |

## SPORTS ART INDUSTRIAL CO., LTD.

- 1-4. Error Message Simulation: No Error Message Simulation
- 1-5. Circumstances of Malfunction: Turn on power; display board immediately shows "ERR9."
- 1-6. Troubleshooting: Run Self-Test to Delete Distance Memory

### Run Self-Test to Delete Distance Memory

First, read the instructions below and be ready for action. A pause at the first step will prevent the self-test process from starting.

1. Turn off the power. Turn on the power. Immediately (while the word "MANUAL" still appears in the LED window) simultaneously press INCL<▲>+INCL<▼>+<ENTER> keys.
2. The display shows "KM". Simultaneously press TIME<▲>+TIME<▼>+DIST<▲>+DIST<▼> keys to enter the self-test mode (Figure 1-8).
3. The unit starts a self-test procedure:
  - (a) The top row of LEDs in the main screen appears, then the second line, then third, etc., until every row of LEDs has been tested.
  - (b) Rows of zeroes appear in the LCD displays, then ones, twos, etc., up to nine. An "8" skits across the LCD windows.
  - (c) In the main screen, "S3C46 TEST" appears, then "...", then "OK".
  - (d) Next every key is tested. The main screen shows "INCL▲". Press INCL<▲> key. Then "INCL▼" appears. Press INCL<▼> key. Press keys as directed through tests on incline, time, distance, speed, race, manual, interval, and program keys. When the main screen shows "STOP1", press the left pause/stop pad. When it says "ENTER", press the enter key. When it says "STOP2", press the right pause/stop pad.
  - (e) The main window shows "Motor Test" then "0.1 MPH" as the motor moves briefly. Then the main window shows "INCLINE TEST", then "UP" as the up incline starts operating, then "DOWN" as the down incline starts operating.
  - (f) The main window shows ENTER RESET. Press the enter/reset key for three seconds. The self-test process ends. Zeroes appear on the LCD windows. The LED window shows the usual commands.
4. Turn off the unit. Turn on the unit. If the operation was successful, ERR9 will not appear.

# 6150E Display at Self-Test Prompt

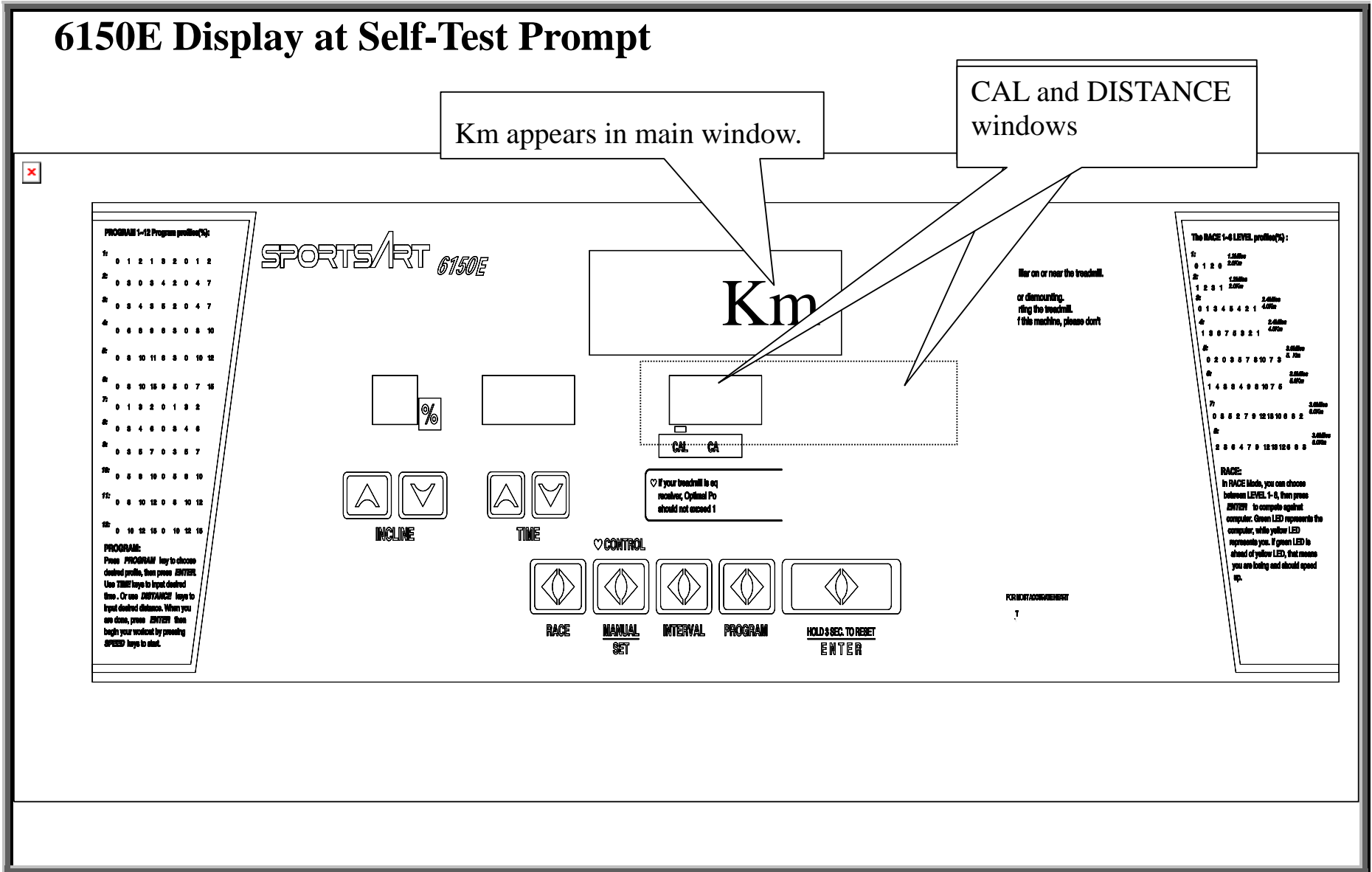

### 1-8. 6150E Display Self-Test Function

1. Press INCL<▲>+INCL<▼>  
>+<ENTER> keys  
simultaneously. The first row  
of LEDs lights, then the  
second, etc.

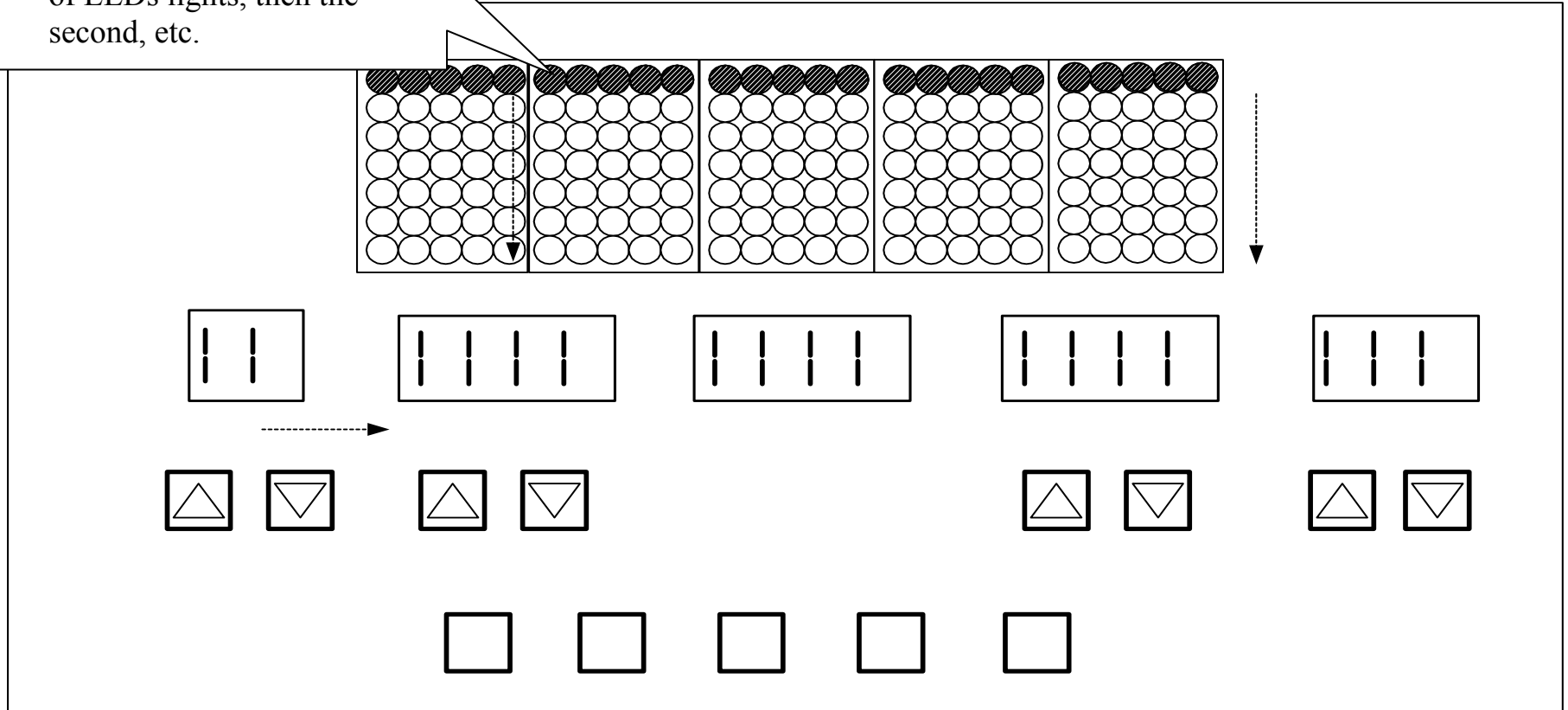

**1-9. 6150E Display: Keypad Operation Test**

Keypad Operation Test shown above. After that, TIME, CAL, DISTANCE windows show "0", indicating that distance has been erased.

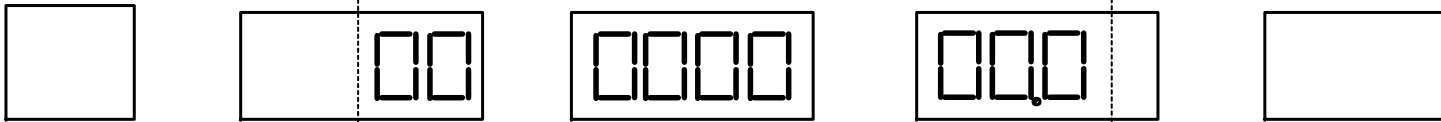
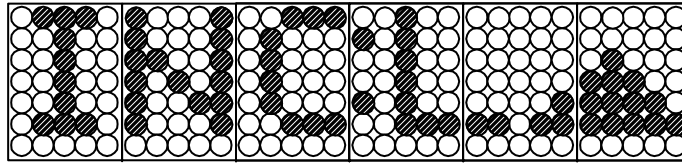

## 1. Resolving ERR9 in a 6150 Treadmill

1.1 Cause: When the accumulated distance run exceeds 30,000 miles (48,000 kilometers), ERR9 appears, reminding the user to do maintenance work, replacing the treadmill belt, the drive belt, etc.

1.2 Response: After carrying out routine maintenance, erase the ERR9 message as follows.

## 2. How to Erase the ERR9 Message in a 6150 Treadmill

2.1 Turn on POWER.

2.2 Enter the distance mode.

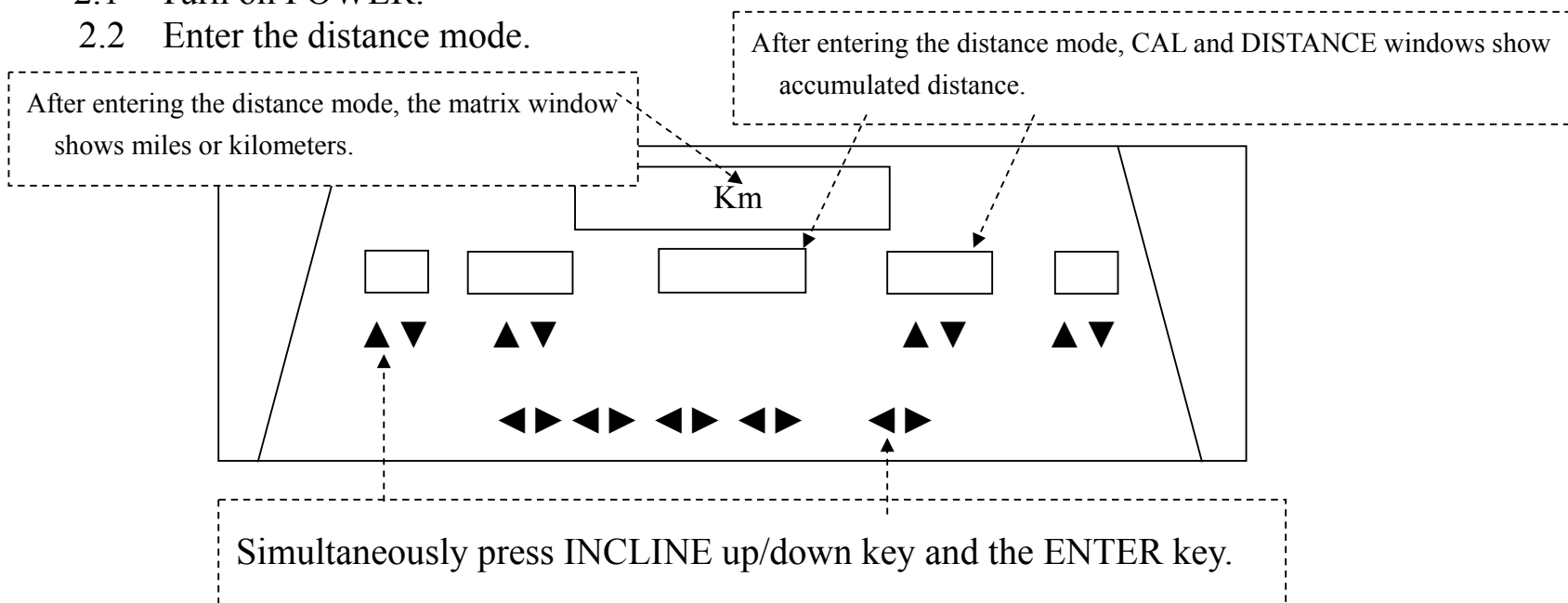

# SPORTS ART INDUSTRIAL CO., LTD.

## 2.2 Erase the Distance Display

After entering the erase distance mode, the matrix display shows from high to low and gradually shows the window value.

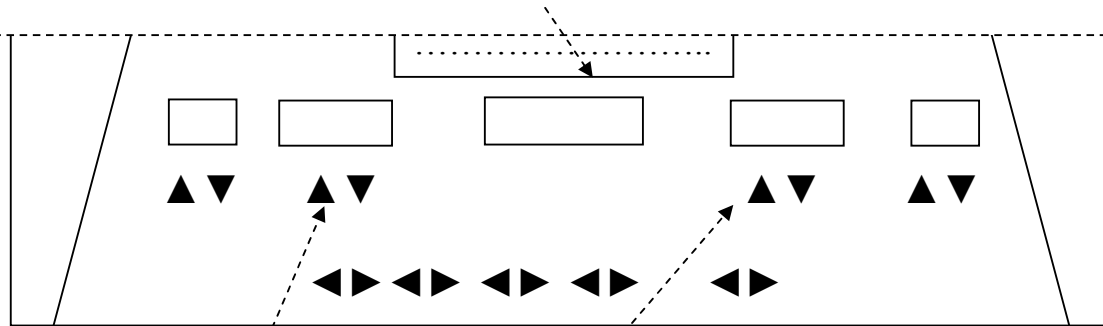

Simultaneously press TIME up/down key and DISTANCE up/down key (altogether 4 keys) to enter erase distance mode.

2.3 While the display window shows values, turn off the unit power, completing the ERR9 erase process.

## 6100/E/6150/E Error Message : ERR 10

### 1. Definition

When the display board detects that the motor is speeding upwards uncontrolled, ERR10 appears.

### 2. Configuration

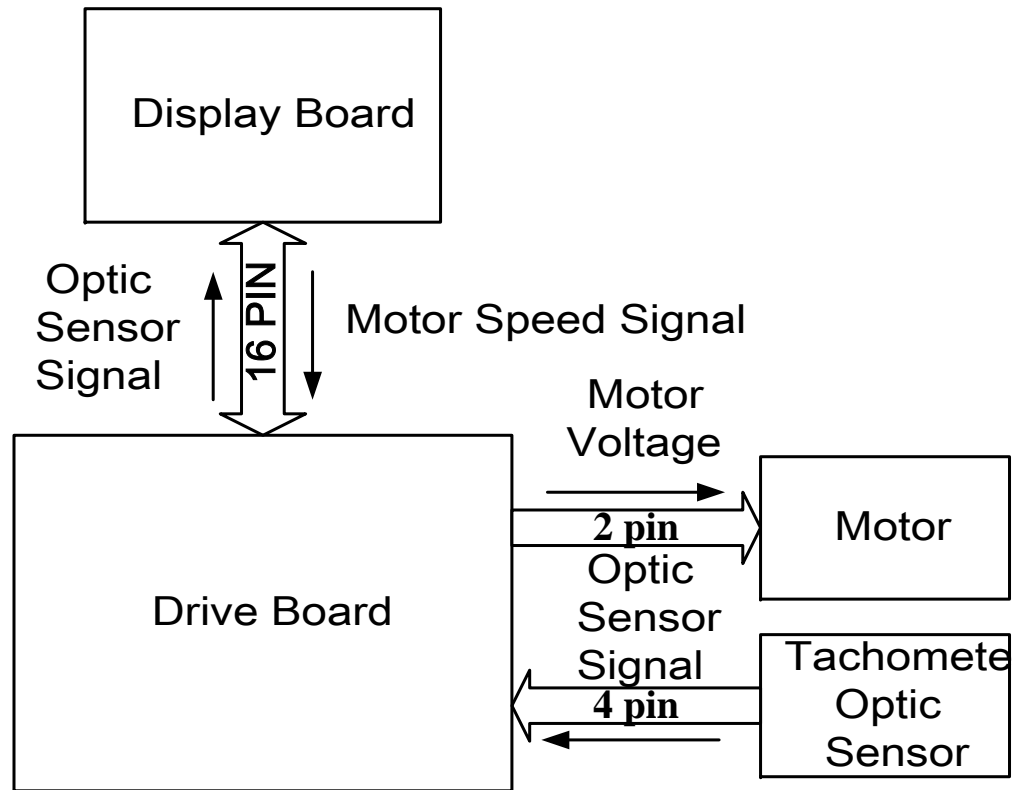



# SPORTS ART INDUSTRIAL CO., LTD.

## 3. Reason for ERR10

1. Turn power on; the motor immediately speeds uncontrolled; ERR 10 appears.

### 1-1. Explanation

The drive board IGBT short-circuited; The drive board immediately sends full power to the motor; So the motor speeds uncontrolled; “ERR10” appears.

### 1-2. Configuration

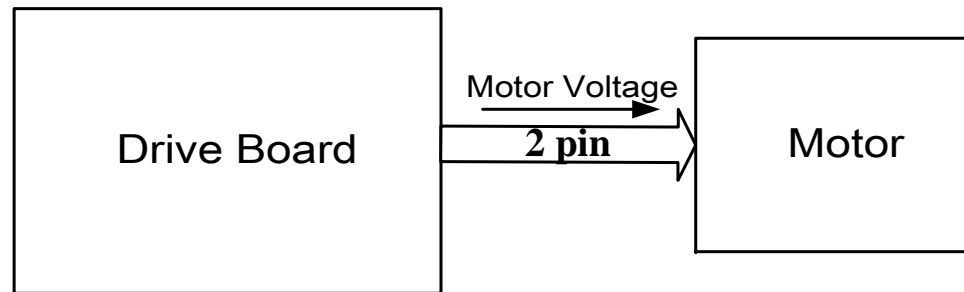

### 1-3. Operation

| Order | Part        | Operation   |
|-------|-------------|---|
| 1     | Drive Board | 1. Turn on power; don't press SPEED key; drive board doesn't send voltage to the motor.<br>2. If the drive board IGBT short-circuits, the drive board sends full power to the motor.                  |
| 2     | Motor       | 1. The drive board doesn't send voltage to the motor; the motor doesn't operate.<br>2. If the drive board sends full power to the motor, the motor speeds full power; "ERR10" appears on the display. |

## SPORTS ART INDUSTRIAL CO., LTD.

### 1-4. Circumstance of Malfunction

(1) Turn on the power. Motor immediately speeds uncontrolled. ERR 10 appears.

### 1-5. Troubleshooting

| Order | Part        | Troubleshooting  |
|-------|-------------|--|
| 1     | Drive board | 1. Remove connections. Test whether the IGBTs have shorted out.<br>2. If so, replace them. |

6100/E/6150/E

## 4. Measuring and Testing

SPORTS ART INDUSTRIAL CO., LTD.

## 6100/E/6150/E Drive Board Switchmode Power Rectifier Testing

### 1. Switchmode Power Rectifier Testing

#### 1-1. Test Configuration

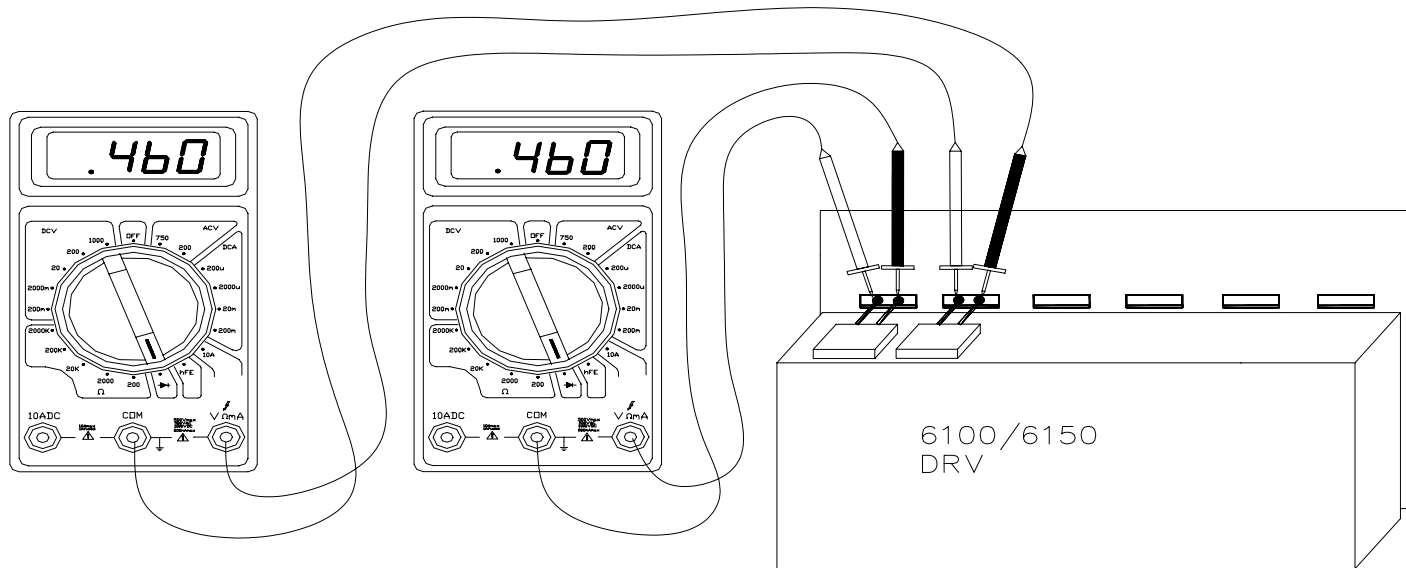

#### 1-2. Test Procedure

- (1) Put multimeter to the Ohm setting (  $\Omega$  ). Place probes as shown.
- (2) If the multimeter shows 0.4-0.6, the component is normal.
- (3) If the multimeter shows 0, the component has a short circuit.

# SPORTS ART INDUSTRIAL CO., LTD.

## 1. Bridge Rectifier Testing

### 2-1. Test Configuration

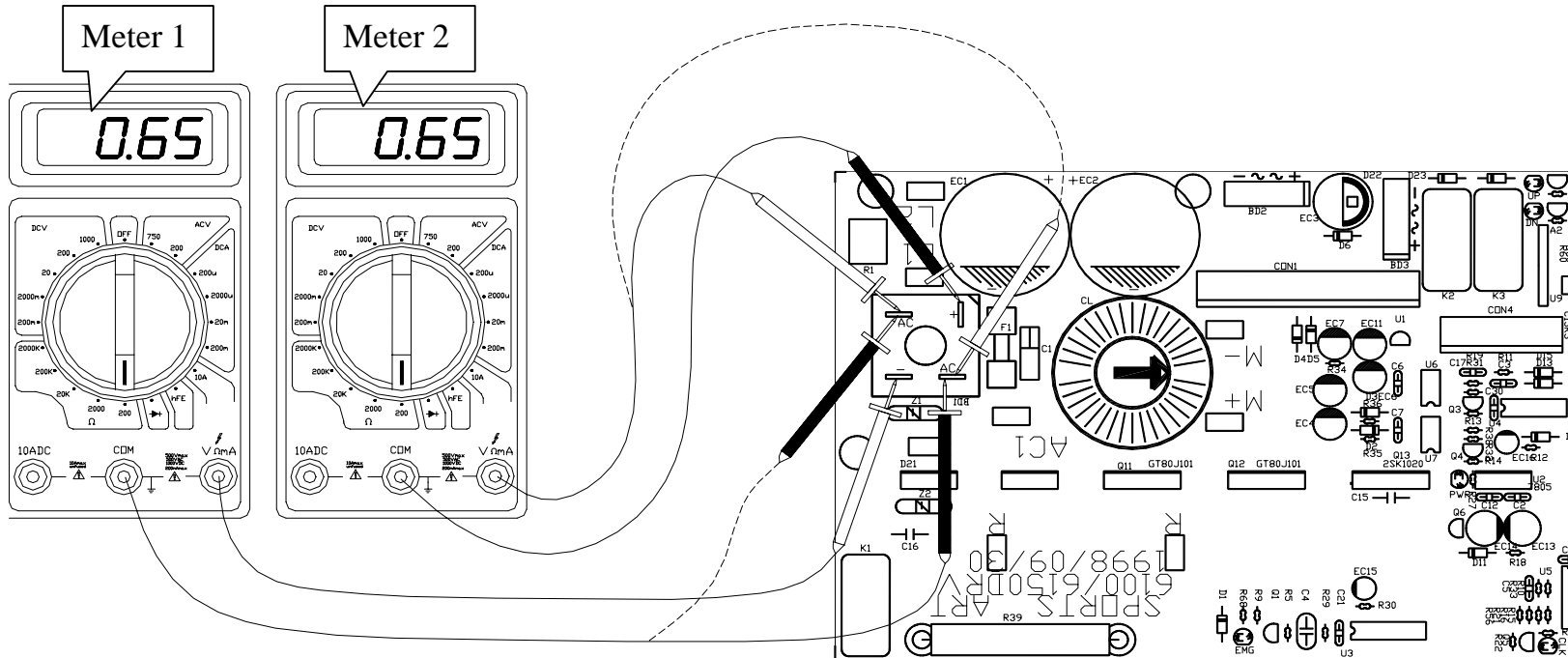

### 2-2. Test Procedure

- (1) Put multimeter to the Ohm setting (  $\Omega$  ).
- (2) Place probes as shown in Meter 1 above. Multimeter should show 0.5-0.8.
- (3) Don't move the black probe. Place red probe on the other pin. The multimeter shows 0.5-0.8.
- (4) Place probes as shown in Meter 2 above.
- (5) If the meter shows 0, the component has a short circuit.

1. IGBT and MOSFET Testing

**3-1. IGBT (Q11,Q12) and MOSFET (Q13,Q14) Testing**

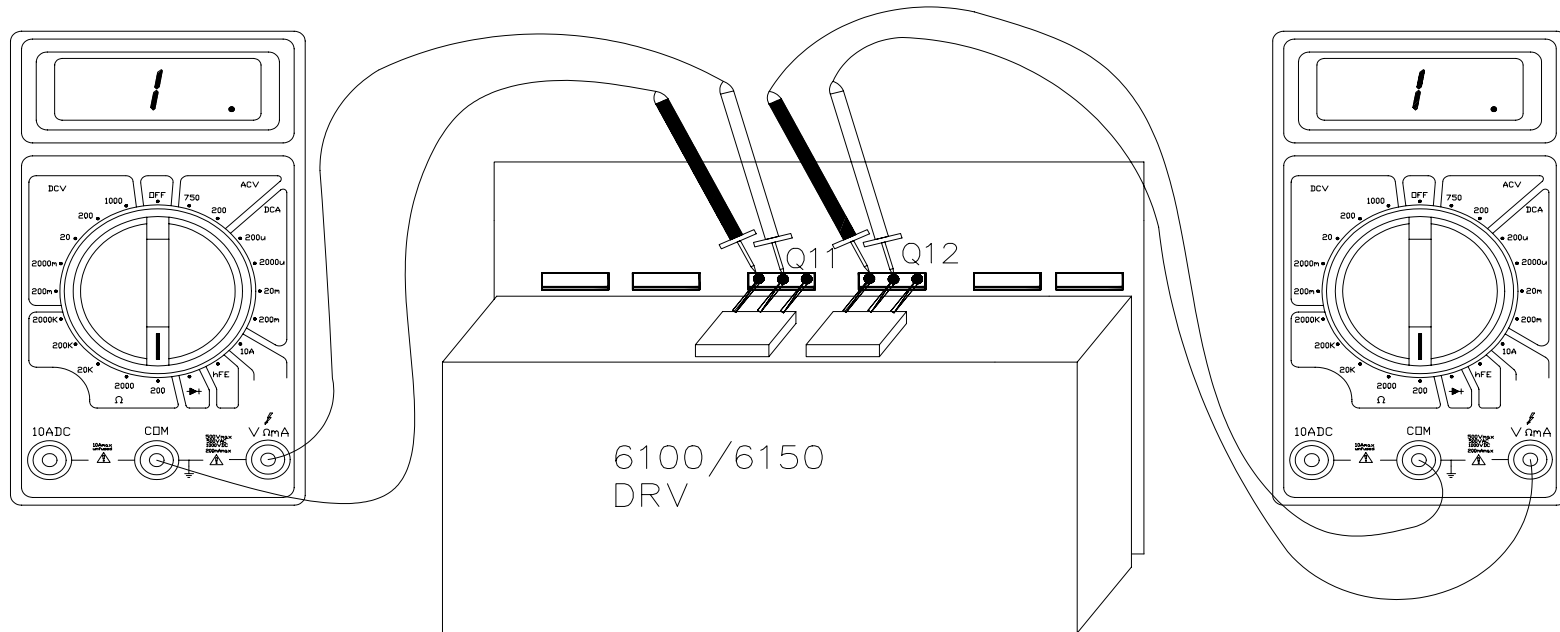

**3-2. Test Procedure**

- (1) Put the multimeter to the Ohm setting (  $\Omega$  ) .
- (2) Place probes as shown above.
- (3) If the multimeter shows 0, the component has a short circuit and is malfunctioning.
- (4) Cut out the IGBT in question and test again.
- (5) Test the MOSFET (Q13,Q14) in the same way.

# SPORTS ART INDUSTRIAL CO., LTD.

## 1. IGBT and MOSFET Testing

### 4-1. Test IGBT (Q11,Q12) and MOSFET (Q13,Q14)

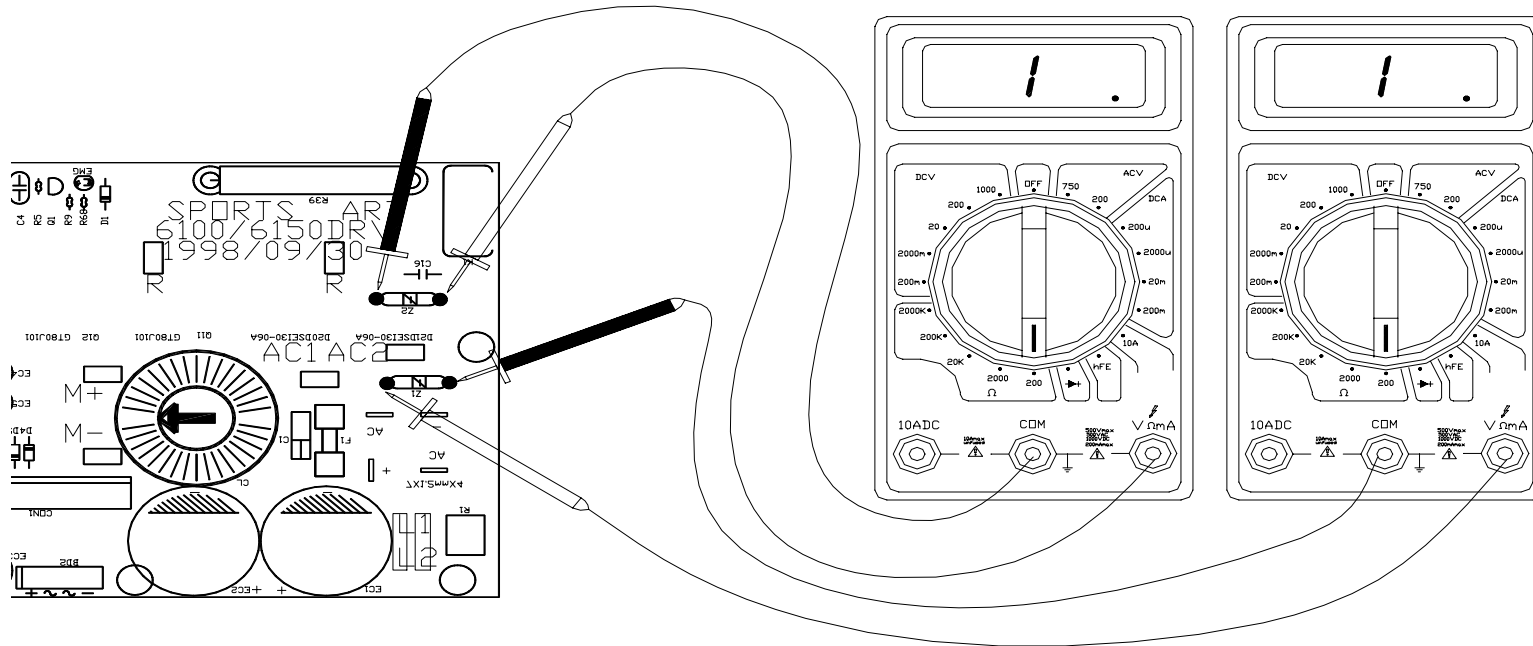

### 4-2. Test Procedure

- (1) Put the multimeter to the Ohm setting.
- (2) Place probes as shown above.
- (3) If the meter shows 0, the component has a short circuit and is malfunctioning.
- (4) Cut out the component in question and test it again.

## SPORTS ART INDUSTRIAL CO., LTD.

### 5. Circumstances of Malfunction

5-1. Turn on power; Power switch doesn't light up; Fuse is broken.

5-2. After turning on power, the drive board EMG LED lights; Press SPEED key; The motor doesn't operate; ERR1 appears.



# 6100/E/6150/E Drive Board Power VCC Test

## 1. Related Component Positions

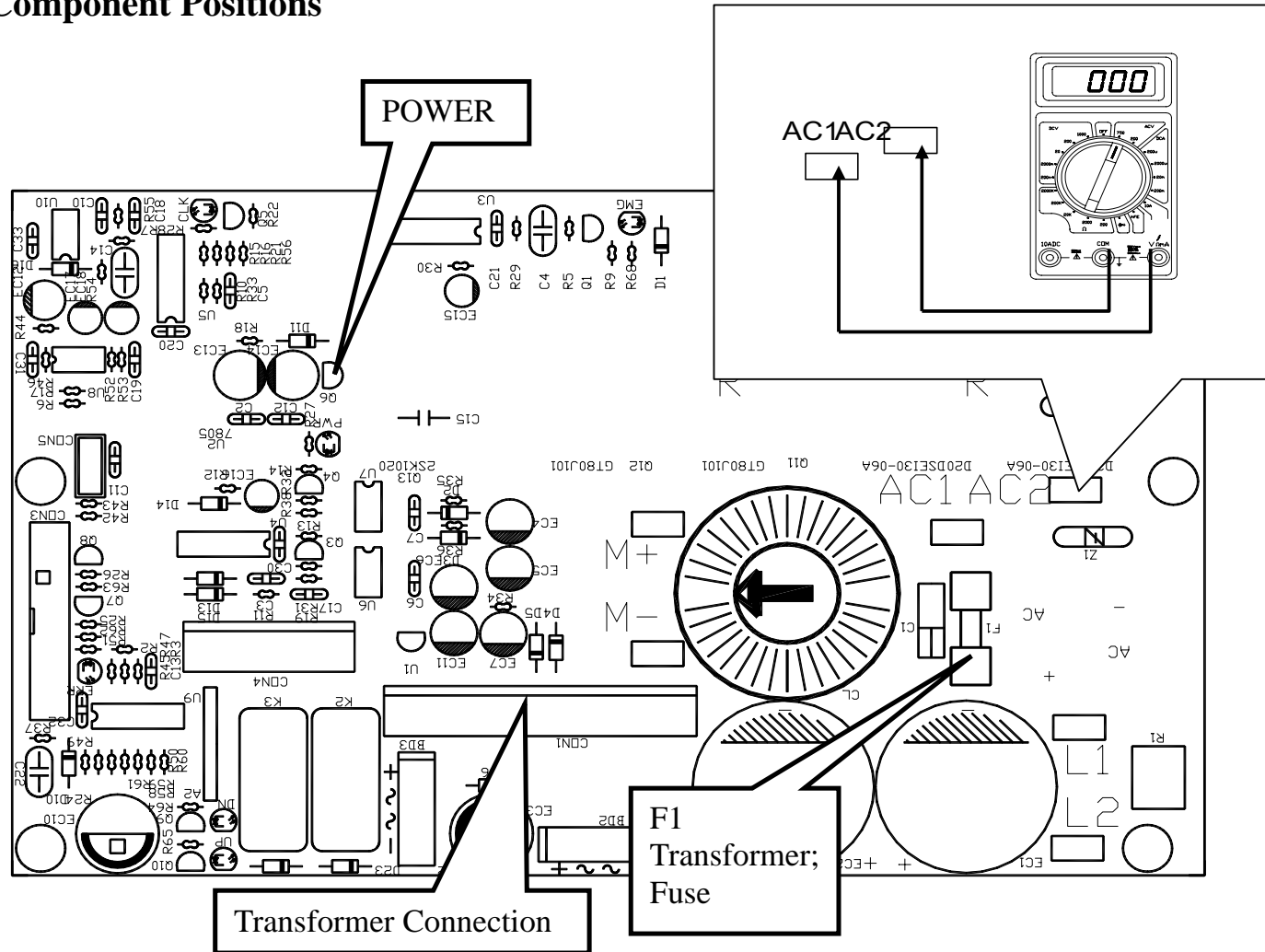

## SPORTS ART INDUSTRIAL CO., LTD.

### **2. Test Procedure**

- 2-1. Turn on power. Power switch lights. If it doesn't light, inspect the main fuse.
- 2-2. If the drive board POWER LED lights, then the board is getting 5VDC on the VCC circuit.
- 2-3. If the POWER LED is not lit,
  - (1) Inspect whether power is coming into the board: Put multimeter to the 750 VAC setting. Place probes on the drive board AC1, AC2 terminals as shown above. The multimeter should show 110V(N. America) or 220V(Europe).
  - (2) Inspect whether the F1 fuse is broken. Replace the fuse.
  - (3) Test whether the transformer is putting out voltage.
  - (4) Remove the 16-PIN cable. If the POWER LED lights, the display board is in question; inspect the display board.

### **3. Circumstances of Malfunction**

- 3-1. Turn on power. If the drive board POWER LED doesn't light, the display board cannot light; the display will be dark.

# 6100/E/6150/E Transformer Test Configuration

## 1. Test Configuration :

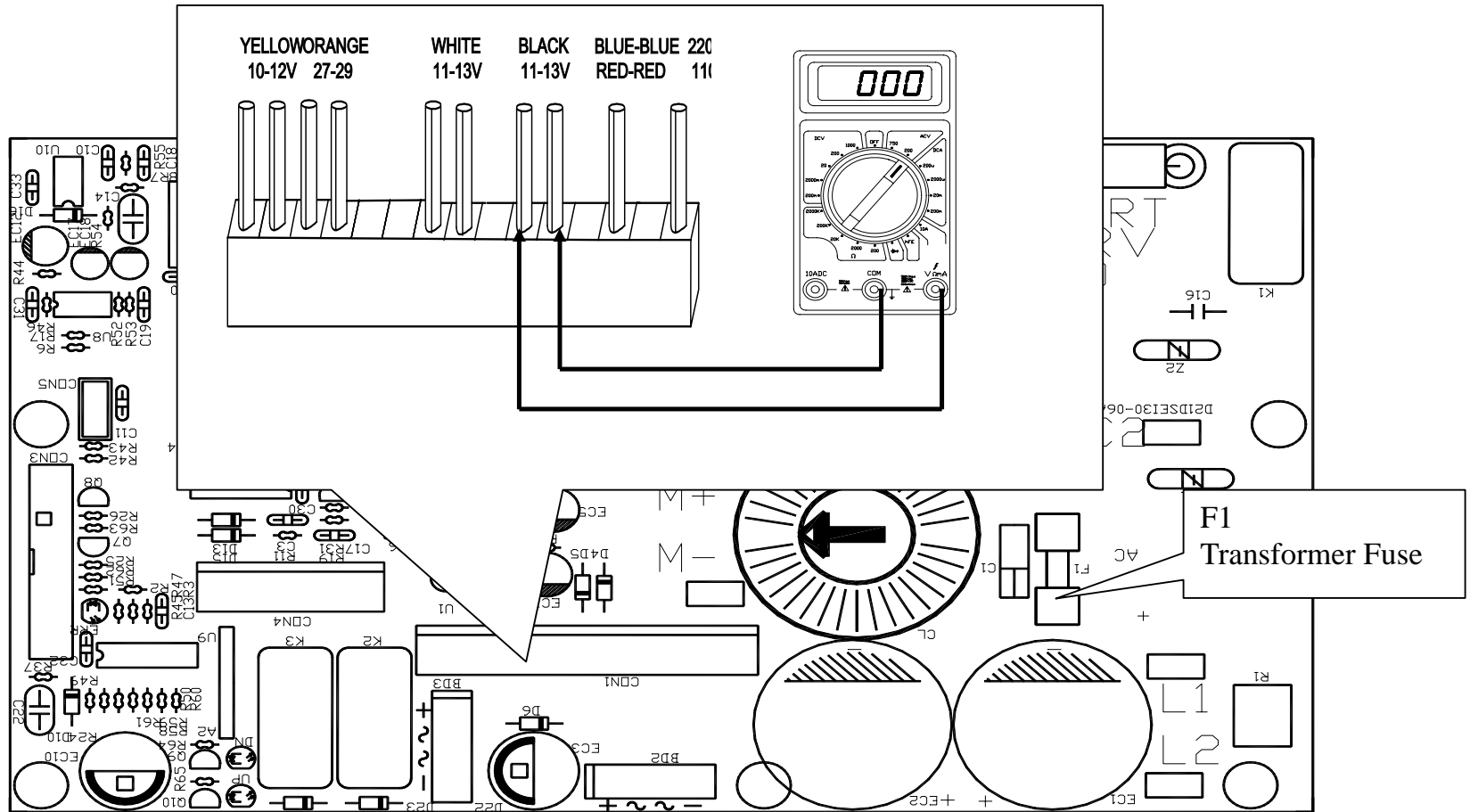

# SPORTS ART INDUSTRIAL CO., LTD.

## 2. Test Procedure

- 2-1. The transformer connects to the CON1 connector on the drive board.
- 2-2. Put multimeter to the AC 200V setting.
- 2-3. Turn on power. Place probes as shown in Figure 1.
- 2-4. Normal voltage: AC 11-13V.
- 2-5. Test the voltage on the following:

| Multimeter |             | Voltage Value |
|------------|-------------|---------------|
| Red Probe  | Black Probe |               |
| BLACK      | BLACK       | 11-13V        |
| WHITE      | WHITE       | 11-13V        |
| ORANGE     | ORANGE      | 27-29V        |
| YELLOW     | YELLOW      | 10-12V        |

## 3. Circumstances of Malfunction

- 3-1. Turn on the power. Power switch lights; drive board POWER LED doesn't light; display doesn't light.
- 3-2. Press SPEED<▲> key; the motor doesn't operate; the display shows "ERR1."
- 3-3. Press INCL<▲> or INCL<▼> key; incline doesn't operate; ERR6 appears.

# 6100E/6150E Drive Board Incline Motor Voltage Test

## 1. Test Configuration

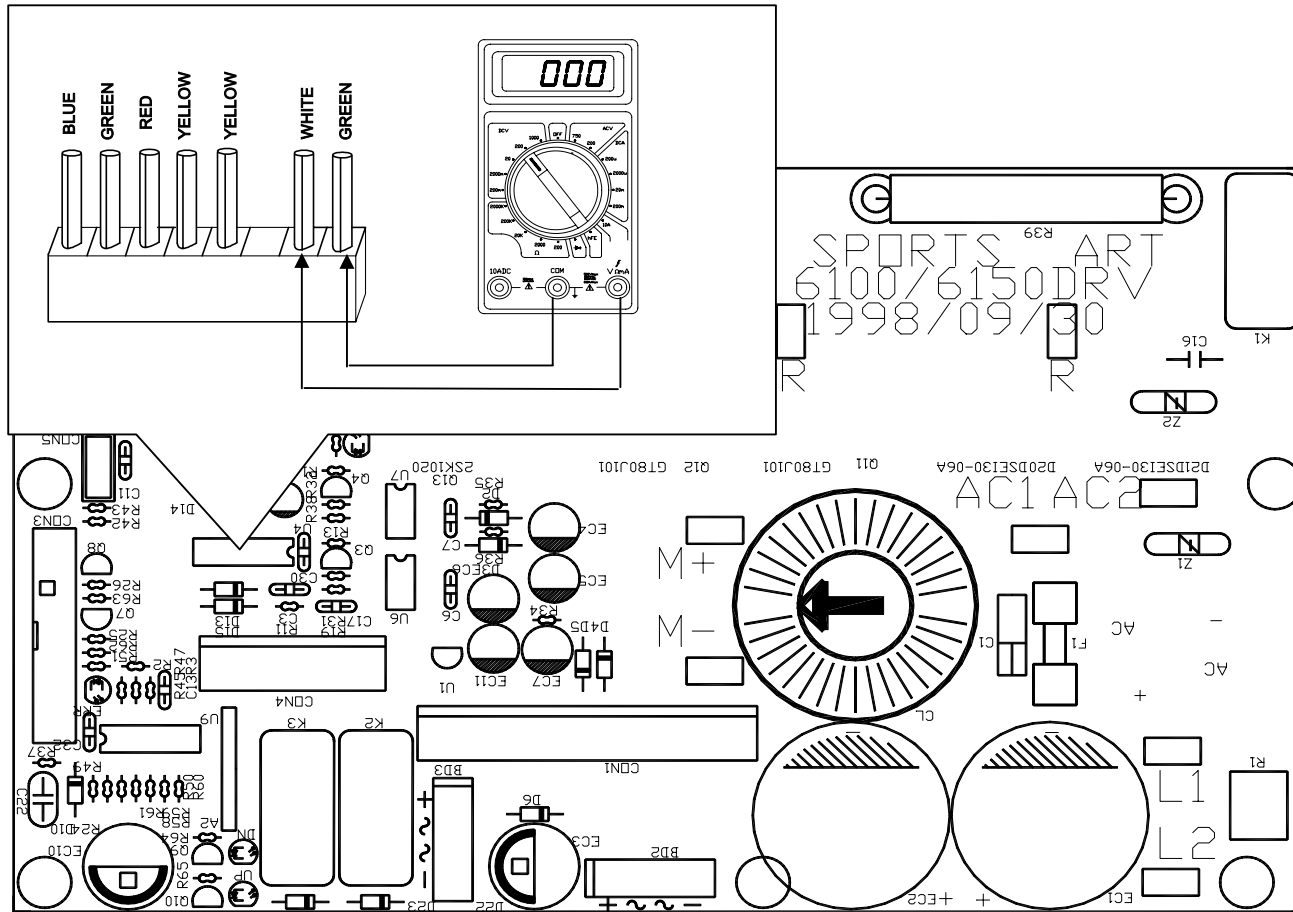

## SPORTS ART INDUSTRIAL CO., LTD.

### **2. Test Procedure**

2-1. Put multimeter to the DC 200V setting. Place the red probe into the CON4-WHITE wire PIN; Place the black probe into the CON4-GREEN wire PIN.

2-2. Turn on power. The display lights up.

2-3. Press INCL<▲> key; Drive board UP LED lights; Multimeter shows +35V or more; Incline operates up.

2-4. Press INCL<▼> key; Drive board DN LED lights; Multimeter shows -35V or more; Incline operates down.

2-5. If the multimeter doesn't get a reading:

- (1) Measure the transformer voltage value.
- (2) If the transformer has voltage, then the drive board is bad.

### **3. Circumstance of Malfunction**

3-1. Press INCL<▲> or INCL<▼> key; incline doesn't operate; ERR6 appears on the display.

# 6100E/6150E Drive Board Incline LIMIT Test

## 1. Test Configuration

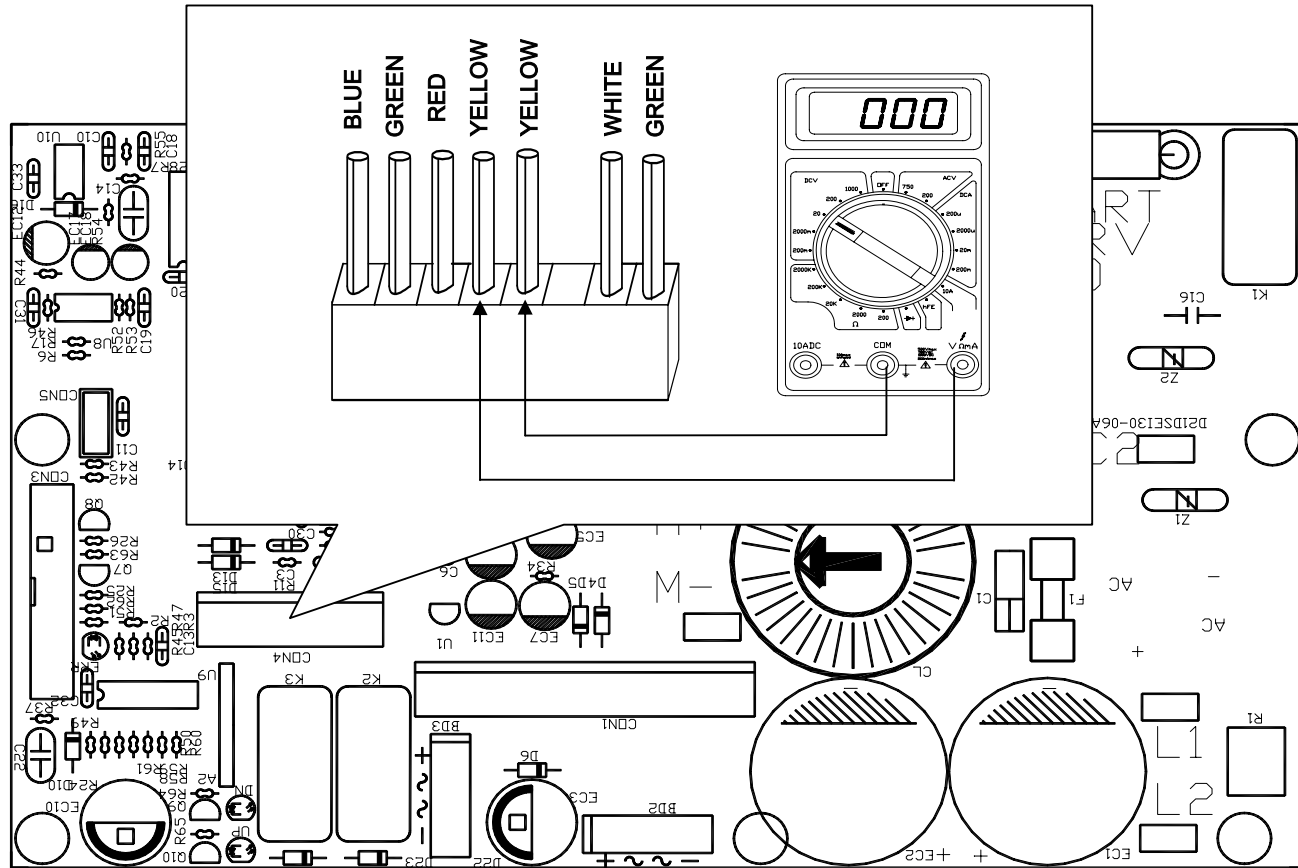

## SPORTS ART INDUSTRIAL CO., LTD.

### **2. Test Procedure**

- 2-1. Put the multimeter to the DC 20V setting. Place probes into the CON4-YELLOW wire PIN.
- 2-2. Turn on power. The display lights up. Multimeter shows 0.0V.
- 2-3. Remove the VR set yellow wire. The multimeter shows 5V. Drive board ERR LED lights.
- 2-4. Re-attach the LIMIT wire. Multimeter shows 0V. Drive board ERR LED lights.
- 2-5. Press INCL<▲> key until the INCL window shows 15%. Incline operates to 15%. Drive board ERR LED doesn't light.
- 2-6. Press INCL<▼> key until the INCL window shows 0%. Incline operates to 0%. Drive board ERR LED doesn't light.
- 2-7. If operating the incline and the drive board ERR LED lights up:
  - (1) Calibrate the incline VR set.
  - (2) Replace the incline VR set.

### **3. Circumstances of Malfunction**

- 3-1. Drive board ERR LED lights; Incline exceeds 0,15% position or gets stuck.
- 3-1. Press INCL<▲> or INCL<▼> key. Incline stops midway.
- 3-2. Press INCL<▲> or INCL<▼> key. Incline display window values change in only one direction.



# 6100E/6150E Drive Board Incline VR Testing

## 1. Test Configuration

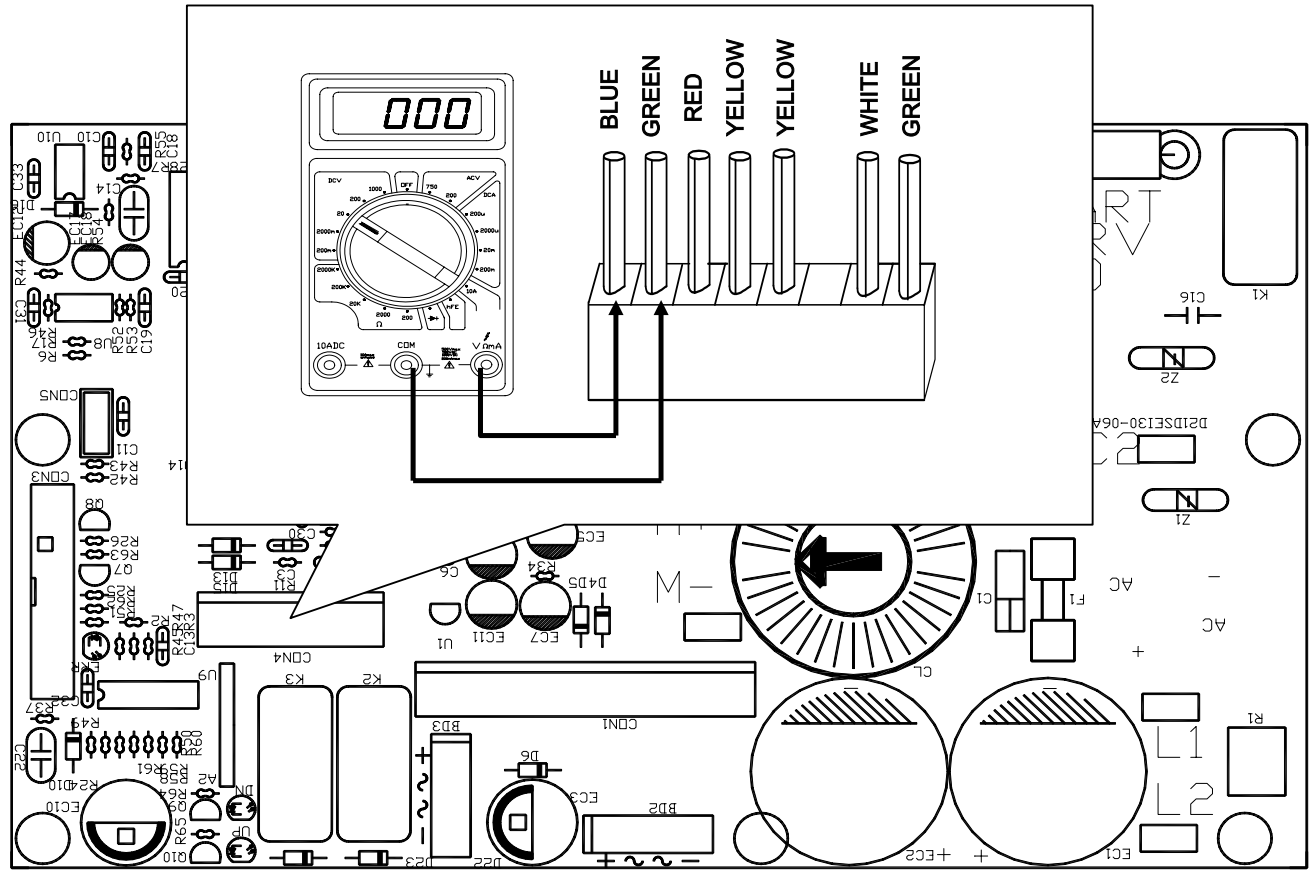

## SPORTS ART INDUSTRIAL CO., LTD.

### **2. Test Procedure**

- 2-1. Put multimeter to the 20 VDC setting. Place probes on the CON4 blue and green wires.
- 2-2. Turn on power. Normal voltage: 1.10V to 3.60. If not in this range, ERR 7 appears.
- 2-3. Press INCL<▲> key until the incline window shows 15%. Incline operates to 15%. Voltage:1.20V.
- 2-4. Press INCL<▼> key until the incline window shows 0%. Incline operates to 0%. Incline set red line shows. Voltage: 3.55V.
- 2-5. If not as in 2-3, 2-4 above, calibrate the VR set and incline position.
- 2-6. In incline action, if the voltage jumps, the VR is unstable. Replace the VR.

### **3. Circumstances of Malfunction**

- 3-1. Incline motor position and INCLINE window differ.
- 3-2 Press INCL<▲> or INCL<▼> key. In incline action, the display shows ERR6.
- 3-2. Press INCL<▲> or INCL<▼> key. In incline action, the motor exceeds the range.

# 6100/E/6150/E Drive Board Motor Voltage Test

## 1. Test Configuration

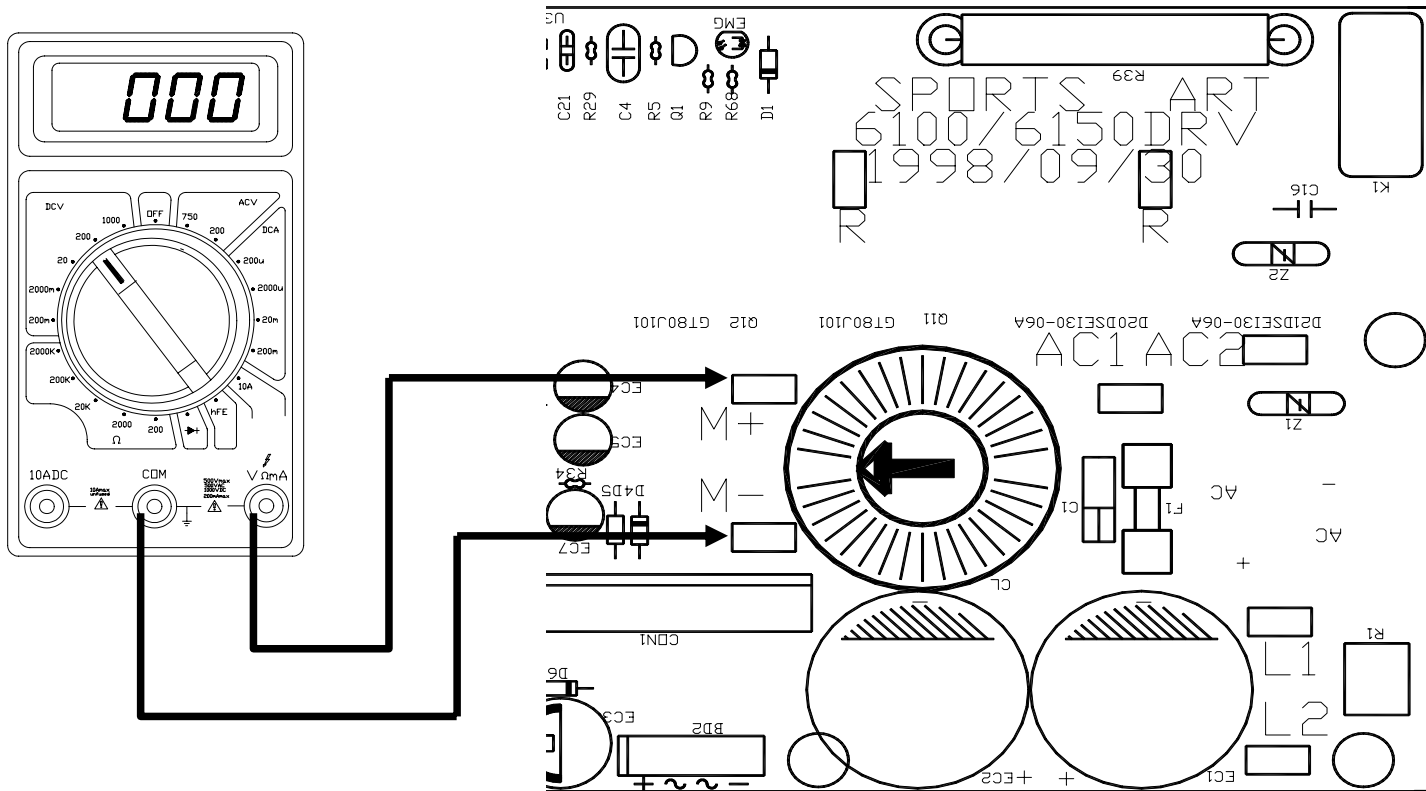

## SPORTS ART INDUSTRIAL CO., LTD.

### **2. Test Procedure**

- 2-1. Set multimeter to the DC 200V setting. Place probes on the drive board M+,M- terminals.
- 2-2. Turn on power.
- 2-3. Press SPEED<▲> key; Multimeter shows voltage; Motor starts operating.
- 2-4. Press SPEED<▲> key until the highest position appears on the display. Motor voltage should be 85-100V (120V models); 180-200V (220 models); 70-90V (Japanese models).
- 2-5. If the multimeter shows no voltage, the drive board is not sending power to the motor.
- 2-6. If the multimeter shows voltage, and the motor doesn't operate, the motor is malfunctioning.  
Test motor.

### **3. Circumstance of Malfunction**

- 3-1. Press SPEED key; Motor doesn't operate; ERR1 appears.

# 6100/E/6150/E Optic Sensor Test

## 1. Optic Sensor Signal LED Position

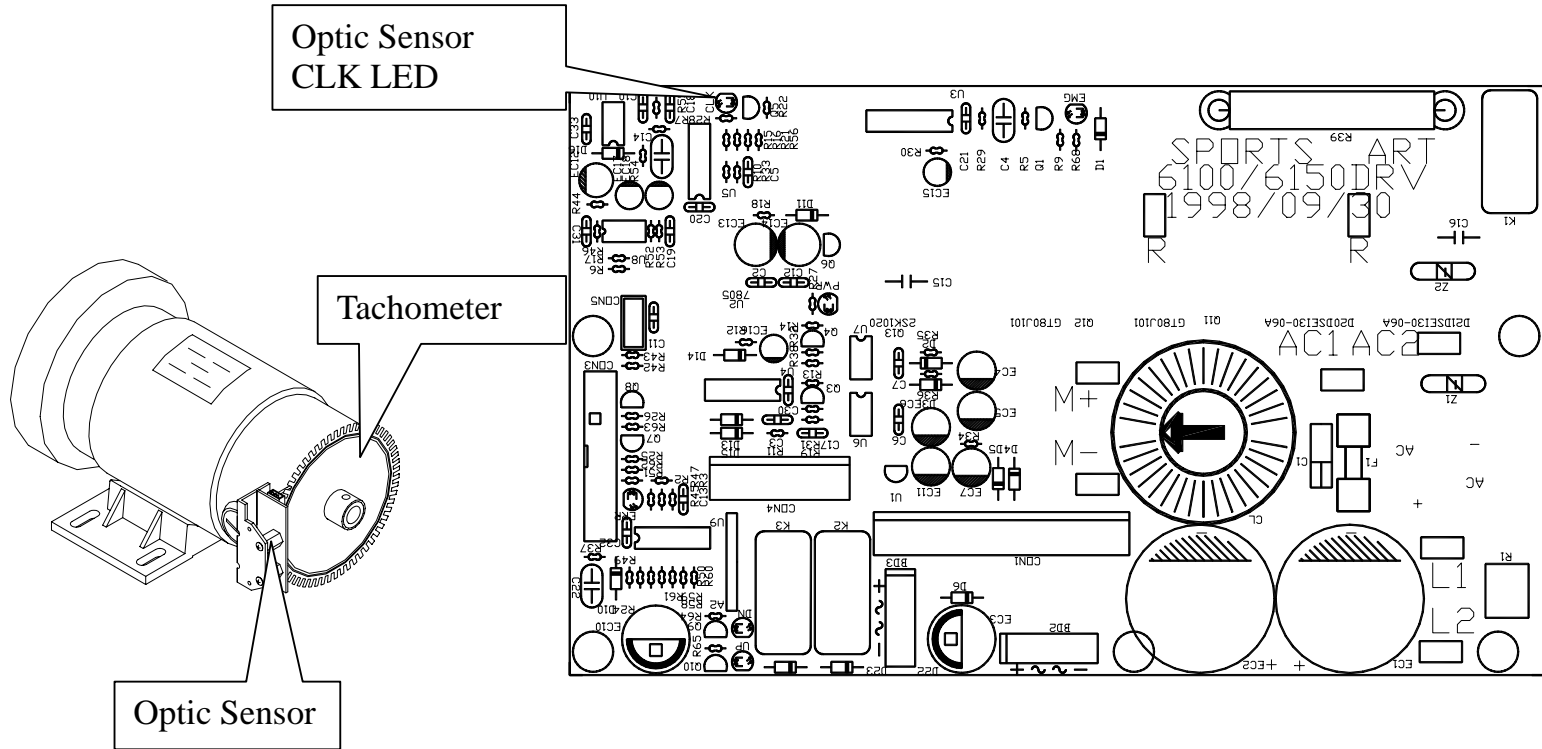

## SPORTS ART INDUSTRIAL CO., LTD.

### **2. Test Procedure**

- 2-1. Inspect whether the tachometer is in the middle of the optic sensor, whether the teeth are in tact.
- 2-2. Inspect whether the optic sensor cable is connected properly.
- 2-3. Turn on power. Don't press any key.
- 2-4. Turn the motor; Drive board CLK flashes.
- 2-5. If CLK doesn't flash, the optic sensor is bad. Replace it.

### **3. Circumstance of Malfunction**

- 3-1. Press SPEED key; the motor speeds uncontrolled; ERR1 appears.

## 6100/E/6150/E Large Resistor Test

### 1. Test Configuration

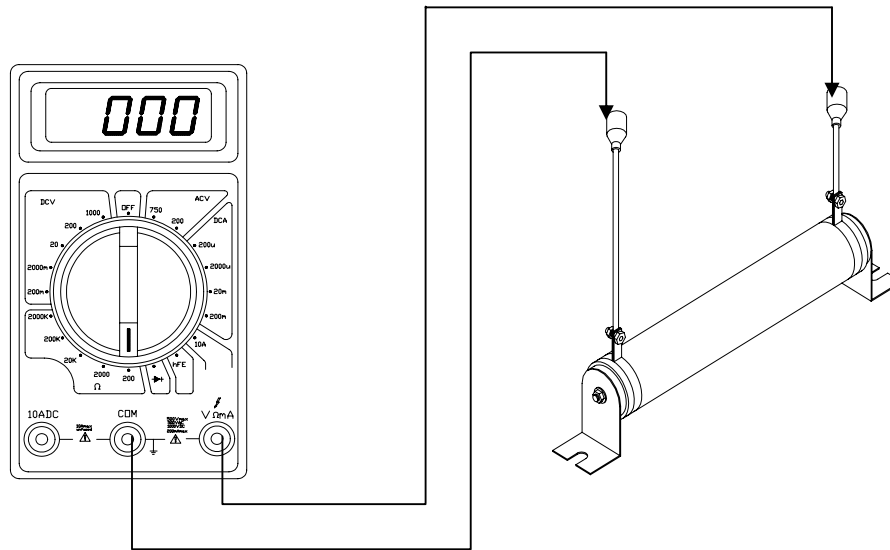

### 2. Test Procedure

2-1. Remove the large resistor.

2-2. Inspect whether the large resistor fuse is broken. If so, replace it (110V models:10A; 220V models: 5A)

2-3. Put multimeter to the 200 Ohm setting. Place probes on the large capacitor terminals.

2-4. The multimeter should show 1.5 Ohms (110V models) or 10 Ohms (220V models).

2-5. If not as above,

(1) Inspect whether the large resistor has a broken circuit.

**3. Circumstance of Malfunction**

3-1. Press SPEED key. When the walk belt is pulled along, there's no resistance. Display shows ERR3.



## 6100/E/6150/E Inductor Testing

### 1. Measuring Voltage

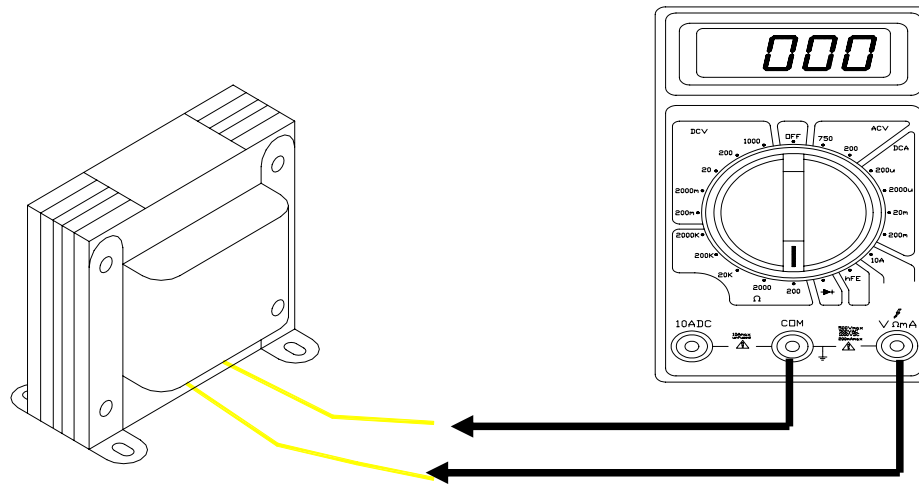

### 2. Procedure

2-1. Remove the inductor wires.

2-2. Set the multimeter to read Ohms. Place probes on the inductor L and L wires.

2-3. The reading should show 10 Ohms or less.

2-4. If no reading appears on the multimeter, the inductor has a broken circuit. Inspect whether the inductor wire has a broken circuit.

(1) Inspect whether the large resistor has a broken circuit.

**3 . Circumstance of Malfunction**

3-1. Press SPEED key. The treadmill belt doesn't rotate. ERR1 appears on the display.

# 6100E/6150E Display Board VCC Measurement

## 1. Configuration

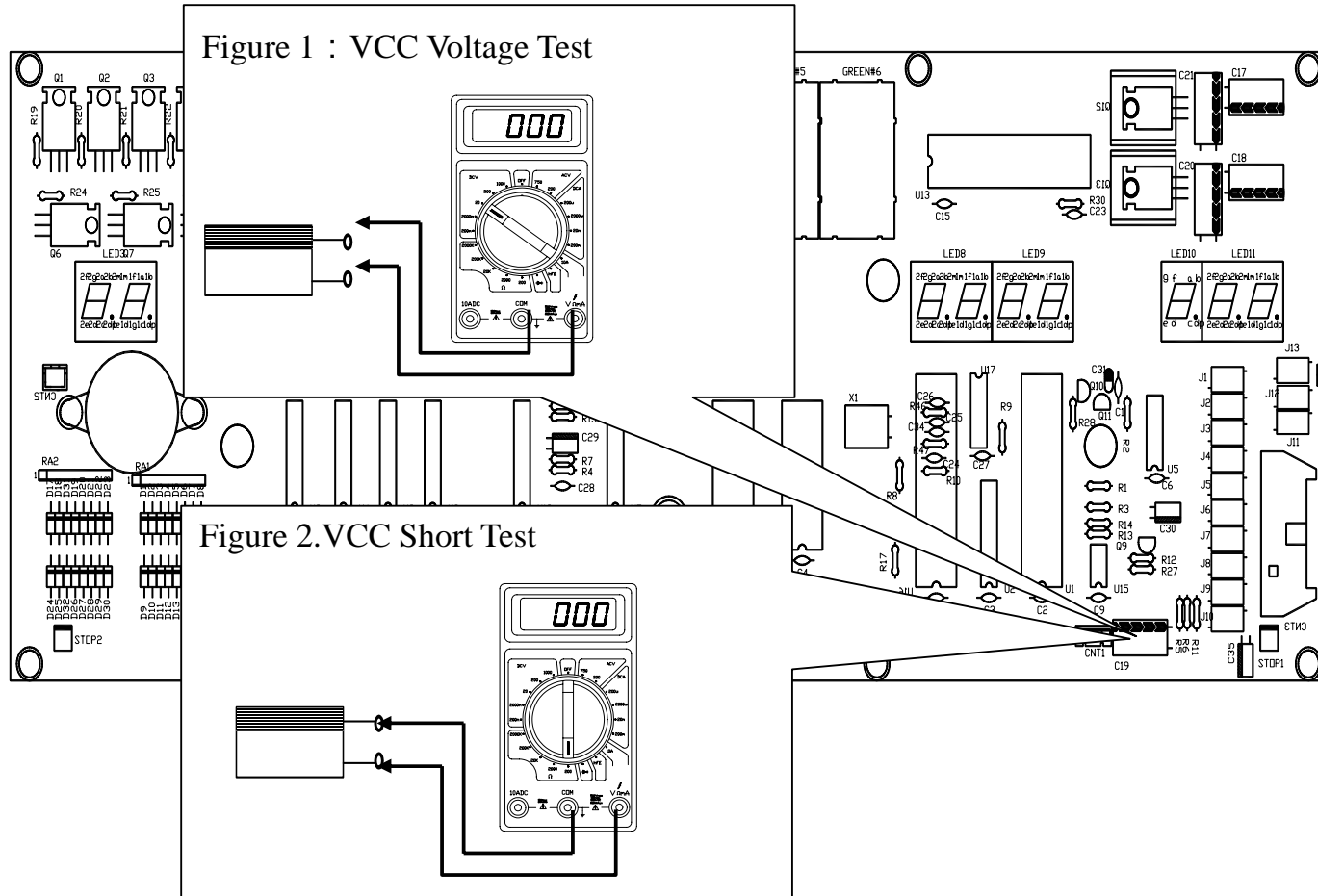

## SPORTS ART INDUSTRIAL CO., LTD.

### **2. Test Procedure**

- 2-1. See Fig. 1. Put multimeter to the 20 VDC setting.
- 2-2. Turn on unit power. Place probes as shown.
- 2-3. Normal reading: 5 VDC. Display beeps once and lights up.
- 2-4. If there is no voltage and the display doesn't light, put multimeter to the Ohm setting. Place probes as shown in Fig. 2. If the multimeter shows a reading like 0 or 0.4, the display board has a short. Replace it.
- 2-5. If the multimeter reads 5 VDC but the display doesn't light, replace the display IC.

### **3 . Circumstance of Malfunction**

- 3-1. Turn on power. Display doesn't light up. Unit will not turn on.

# 6100E/6150E Display STOP Board Testing

## 1. STOP Board Test Configuration

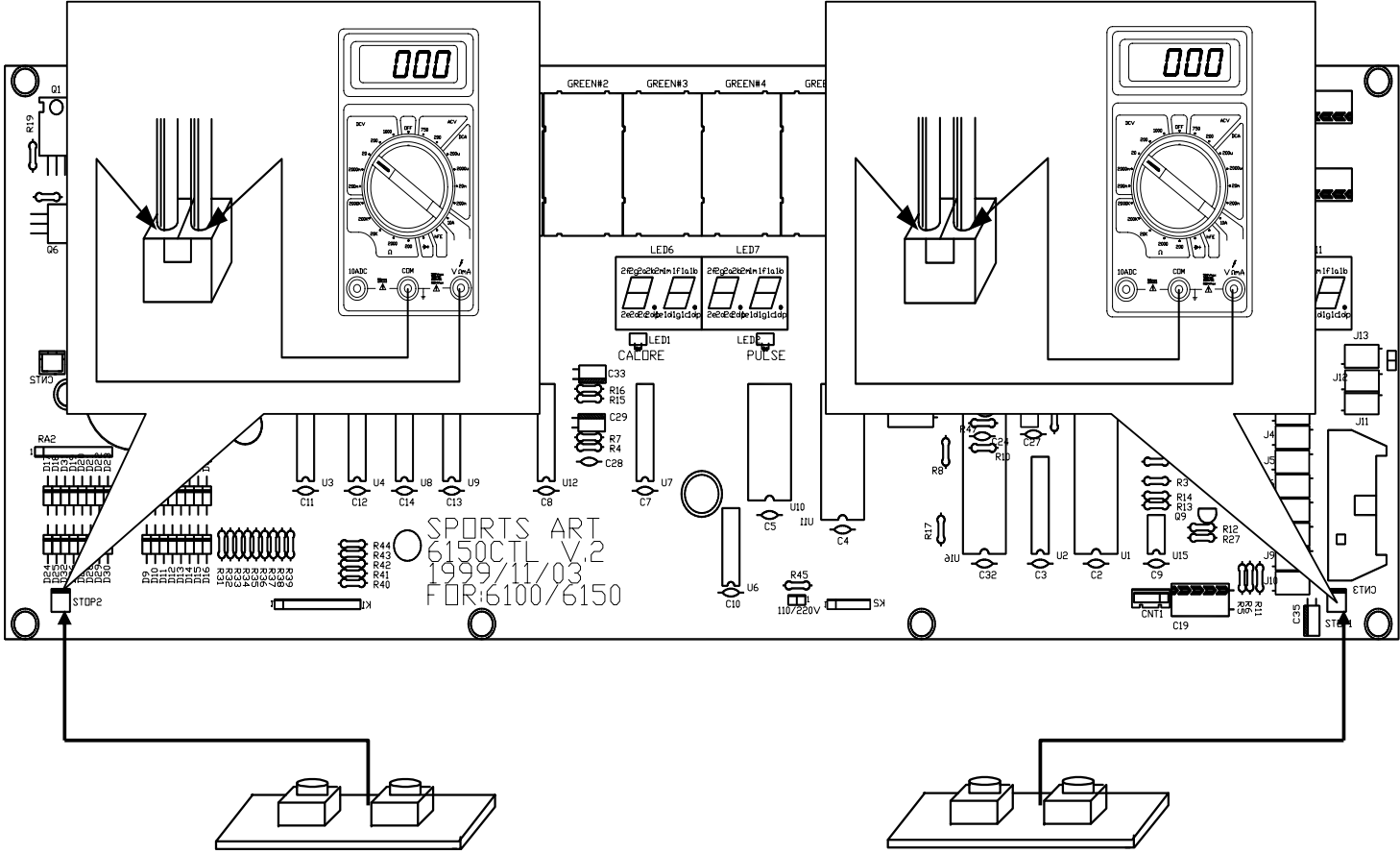

## SPORTS ART INDUSTRIAL CO., LTD.

### 2. Test Procedure

2-1. Turn on power. Display shows “MAN’L”. SPEED window flashes.

2-2. Place the multimeter to the 20 VDC setting. Place probes on the STOP board connectors as shown below.

2-3. Don’t press the STOP switch. Voltage: 5 VDC.

2-4 Press the STOP switch. Voltage: 0 VDC. The display beeps once. Turn on the unit.  
Voltage: 5 VDC.

2-5. If readings differ from 2-3 and 2-4 above,

- (1) Reattach the STOP board and switch.
- (2) Inspect whether the STOP switch is attached well.
- (3) Inspect whether the STOP board switch is suck or inoperable.

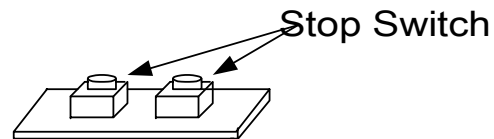

### 3. Circumstance of Malfunction

3-1. Turn on power. Don’t press any key. The display SPEED window doesn’t flash normally.

3-1. Press SPEED window key. After releasing the key, the SPEED window returns to base display.

3-2. In use, the treadmill stops suddenly; SPEED window shows 0.0; the TIME window doesn’t show 00.00.

## 6100/E/6150/E (Old) HTR Board Testing

### 1. HTR Wiring and Signal Position

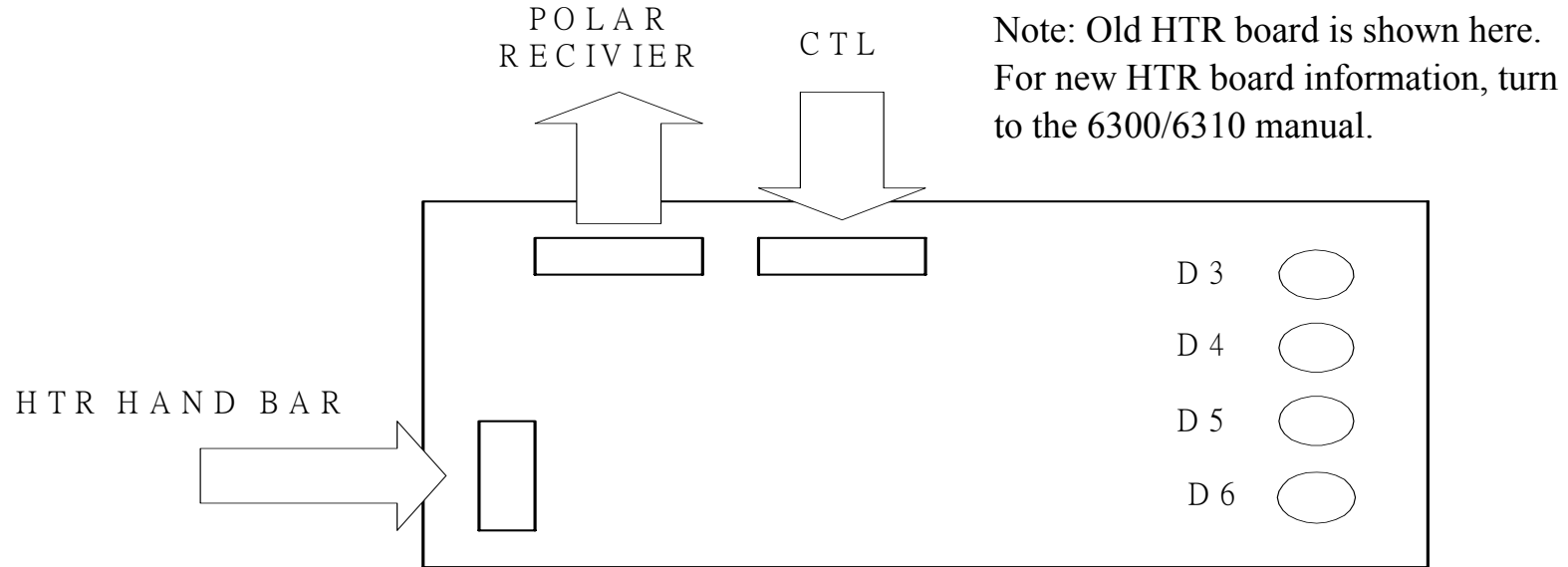

### 2 : Indicator LED Description

| Signal | Color  | Name           | Explanation  |
|--------|--------|----------------|--|
| D3     | RED    | POLAR HR LED   | Flashing light means that the POLAR heart rate signal is entering the board. |
| D4     | YELLOW | HTR Signal LED | Lit light means that the user's hand is on the HTR bar.                      |
| D5     | GREEN  | HTR Pulse LED  | Flashing light means that the HTR signal is entering the board.              |
| D6     | WHITE  | HR output LED  | Each time the light flashes a heart rate signal is emitted.                  |

# SPORTS ART INDUSTRIAL CO., LTD.

## 3 : Test Procedure

### 3-1. HTR heart rate test

3-1-1. Don't touch the HTR bar. The HTR board LEDs don't light.

3-1-2. Hold onto the HTR bar; The HTR board D4 LED lights.

3-1-3. D5 LED flashes, indicating that the HTR bar heart rate signal is entering the board.

3-1-4. D6 LED flashes, indicating that the HTR board heart rate signal is being emitted to the display board.

3-1-5. Within ten seconds, the PULSE window shows the heart rate value.

3-1-6. If not as above, start troubleshooting according to the chart below.

### 3-2. POLAR heart rate test

3-2-1. Put the POLAR transmitter in place. Stand on the treadmill.

3-2-2. If the HTR board D3 LED flashes, the POLAR heart rate signal is entering the board.

3-2-3. A flashing D6 LED indicates that the HTR board signal is being emitted to the display board.

3-2-4. Within ten seconds, the PULSE window shows the heart rate value.

3-2-5. If not as above, start troubleshooting according to the chart below.

| LED Indication         | Reason for Malfunction                             | Malfunctioning Component                  |
|------------------------|--|---|
| D3 not lit             | The POLAR receiver is not detecting a heart rate.  | POLAR transmitter, POLAR receiver, cable  |
| D4 not lit             | HTR bar isn't being held                           | HTR handlebar, HTR board to HTR bar cable |
| D5 not lit             | HTR signal is not entering board                   | HTR handlebar, board to handlebar cable   |
| D6 not lit             | HTR board is not emitting the heart rate value.    | HTR board                                 |
| Display lacks HR value | HTR board signal isn't entering the display board. | 3-PIN cable, display board                |



## SPORTS ART INDUSTRIAL CO., LTD.

### **4. Circumstance of Malfunction**

1. Hold onto HTR handlebar; The display PULSE window shows no HR value.
2. Turn on the unit or in use, the display PULSE window automatically shows a heart rate value.
3. Hold onto HTR handlebar; the display PULSE window HR value and actual heart rate differ too much.
4. Using POLAR strap, the display PULSE window doesn't show a heart rate value.
5. The POLAR heart rate and actual heart rate differ too much.

# 6100/E/6150/E Display POLAR Heart Rate Test

## 1. Test Configuration

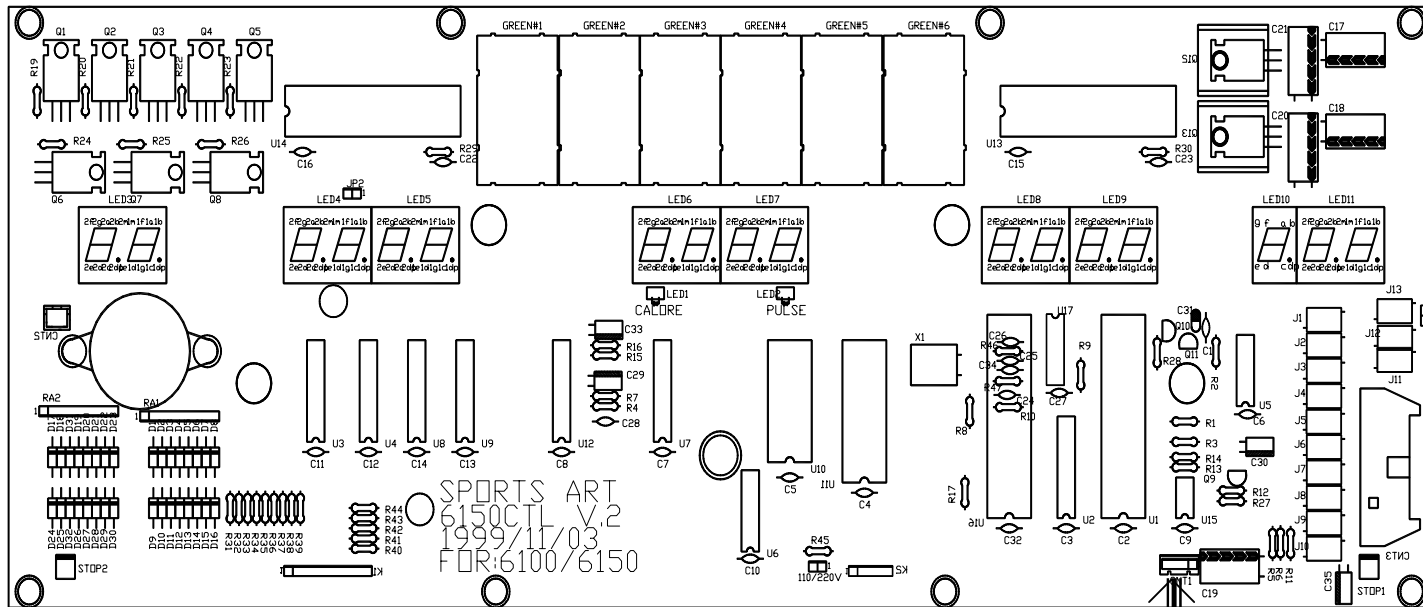

POLAR HR Receive

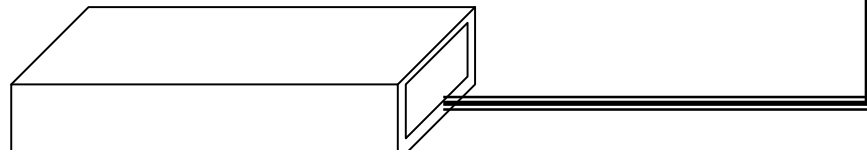

## SPORTS ART INDUSTRIAL CO., LTD.

### 2. Test Procedure

- 2-1. Inspect whether the POLAR receiver wires are connected properly.
- 2-2. Put on the POLAR transmitter.
- 2-3. Turn on the power. Display shows “MAN’L”.
- 2-4. The display PULSE indicator lights up; Within 10 seconds, the PULSE/CAL window shows the heart rate value.
- 2-5. When the heart rate enters the display board, the CAL/POLAR window switches between CAL and PULSE every six seconds.
- 2-5. If no heart rate value appears, inspect
  - (1) Display cable soldering
  - (2) Heart rate cable
  - (3) POLAR receiver and blue antennae soldering
  - (4) Inspect whether the POLAR heart rate transmitter has voltage

### 3. Circumstance of Malfunction

- 3-1. Put on POLAR transmitter. The display PULSE indicator doesn't light; CAL/PULSE window doesn't show a heart rate value.

# 6100/E/6150/E Incline Motor Broken Circuit Test

## 1. Test Configuration

Configuration 1 :

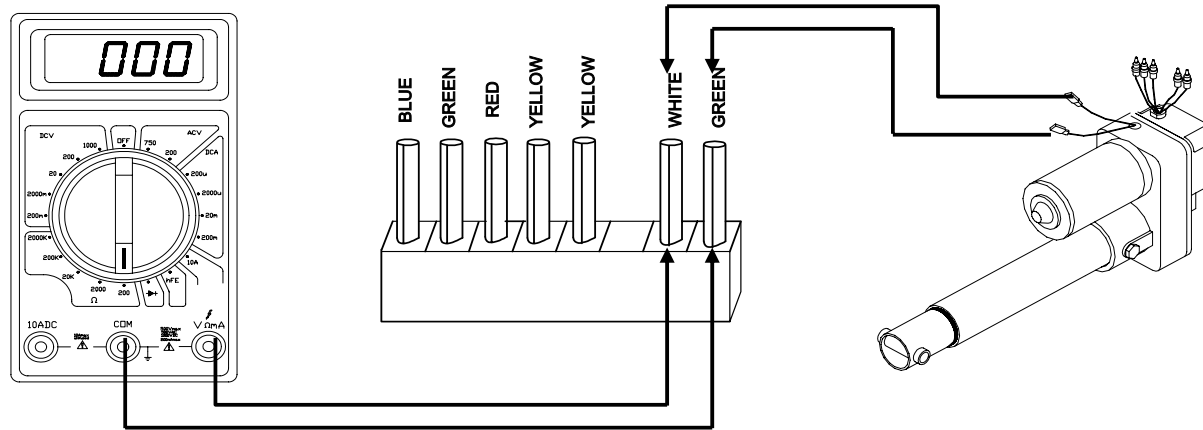

Configuration 2 :

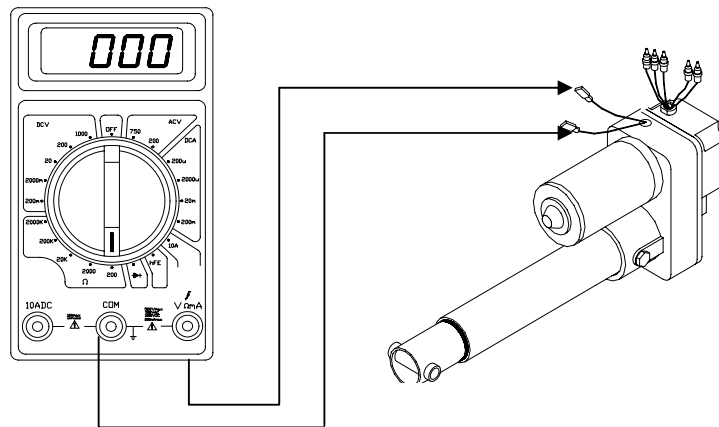

## SPORTS ART INDUSTRIAL CO., LTD.

### **2. Test Procedure**

2-1. Remove the drive board incline wires.

2-2. Put multimeter to the 200 Ohm setting. Place probes on the white and green wires as shown in Configuration 1.

2-3. Normal Ohm reading: One or less Ohm.

2-4. If the multimeter doesn't read a value or has a variable value:

(1) Inspect whether the incline cable is connected properly.

(2) Inspect whether the incline fuse has broken. If so, replace it.

(3) Test whether the incline motor has a broken circuit as shown in Configuration 2. A reading of 1 Ohm or less indicates that the incline motor is normal. If there's no reaction whatsoever, the incline motor is bad.

### **3. Circumstance of Malfunction**

3-1. Press INCLINE<▲> or INCLINE<▼> key; No incline operation; ERR6 appears on the display.

## 6100/E/6150/E Motor Short Circuit Test

### 1. Test Configuration

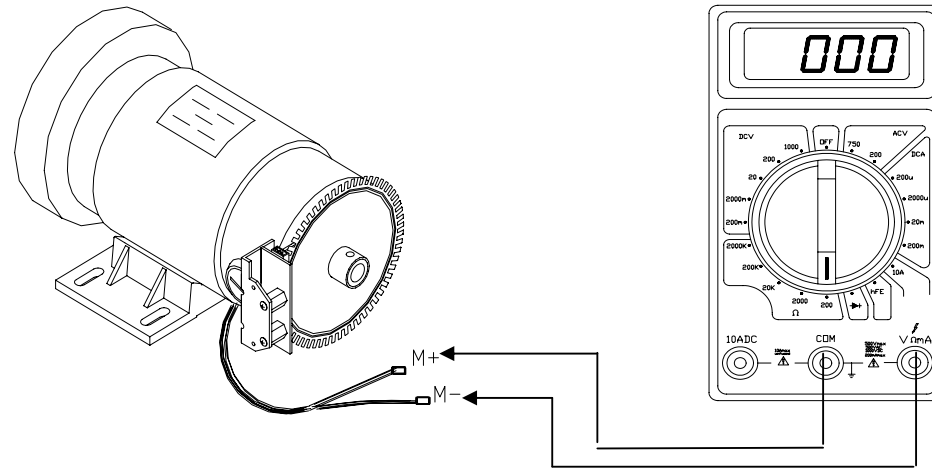

### 1. Test Procedure

- 2-1. Remove the drive board motor M+, M- wires.
- 2-2. Put the multimeter to the 200 Ohm setting. Place probes on the M+ , M- wires.
- 2-3. Normal reading: 1 Ohm or less.
- 2-4. If the multimeter shows no reaction or a variable value, the motor internal circuit is broken. Inspect:
  - (1) the motor brush;
  - (2) the axle.

**3 . Circumstances of Malfunction**

3-1. Press SPEED key; Treadmill belt doesn't move; Display shows ERR1.